Operating instructions

Industrial Piston Air Compressors Motor Driven Package

V8071-205

Pump Model: LP205

Motor: 7.5 HP / 1 PH

Air Tank: 80 Gal

7502 Mesa Road Houston, TX77028

Telephone: (713) 635-6331

E-mail: service@lapante.com

Web Site: www.laplantecompressor.com



Contents	Page
Introduction	1
Unpacking and handling	2
Appropriate use	4
Symbols used	5
Symbols used	5
Symbols on the package	6
Safety guide	8
Technical Data	10
Specification	10
Explode drawing	11
Bom list	12
Section I	
Pump	
Installation instruction	1
Technical data	1
Outline drawing	2
Explode drawing	3
Bill of material list	4
Operation	14
Parts kits	1
Overhaul Kit	1
Ring Set	1
Valve Set	1
Gasket Set	1
Disassemble pump	2
Assemble pump	2
Troubleshooting	4
Maintenance	7
General	7
Safety information	7
Check oil level	8
Check and clean compressor valves	8
Check the safety valve	10
Change oil	11
Check and change air filter	14
Maintenance intervals	15
List of Maintenance and service work	16

Section II

Motor

Receiving and inspection	1
Storage	1
Installation	1
Installation - Mechanical	2
Installation - Electrical	2
Operation	3
Maintenance	3

Section III

Check Valve

General	1
Safety information	1

Section IV

Air Tank

General	1
Safety information	1
Check the safety valve	2
Condensate	2

Section V

V-Belt

General	1
Safety information	1
Maintenance intervals	1

Section VI

Magnetic Starter

General	1
Safety information	1
Countermeasures for normal malfunctions	2
Pressure Switch	6

Section VII

Wiring Diagram	1
----------------------	---

List of Maintenance and service work	16
---	----

Introduction

These operating instructions form part of the machine and must be made available to the compressor operating personnel at all times. In order to receive maximum performance and long life from your compressor, the following instructions should carefully read and all points regarding installation and operation of the unit should be noted and observed .careful reading of this manual, prior to connecting anything to the motor or compressor, will pay dividends in long term trouble-free operation.



Unpacking and Handling



Occasionally damage will occur during shipping. Be sure to carefully inspect the unit before unpacking and after unpacking **BEFORE** you sign the receiver. If any has occurred, document it with the trucking firm immediately. Contact your LAPLANTE representative for assistance.

To move your compressor to its installation site we recommend that you leave the unit on its shipping skid as long as possible. The forks should be extended the width of the compressor and padding should be placed between the compressor and the fork truck boom.

If it is necessary to lift the compressor with a crane, we recommend the use of spreader bar and chains. The spreader bar should be greater than the width of the compressor and padding placed on the edges to prevent chain damage.



DO NOT UTILIZE THE PUMP OR DRIVE AS A LIFT POINT

Procedure for Handling Damaged Shipments

1. The customer, at the receiving point, **MUST** inspect each shipment for damage.
2. If the shipment is damaged, the customer should so note it on the freight bill.
3. The customer should request an inspector from the freight company to inspect the equipment immediately. It is best to send a confirming letter with the following information:
 - a. Freight bill number.
 - b. Date delivered - shipper's name & address.
 - c. Description of item(s) damaged.
 - d. Description of damage (a Polaroid picture if possible).
 - e. A copy of your invoice for the equipment.
4. After inspection, (before the inspector leaves):
 - a. Get a copy of the inspection report.
 - b. Request the unit be shipped back "free astray".
 - c. Request a credit for the original freight bill.
5. Call the factory and:
 - a. Get a Return Material Authorization (RMA number).
 - b. Give a purchase order for repair. The purchase order should refer to the item and trucker claim.



6. We will accept the shipment back, repair (under normal conditions) and return it within (7) seven working days.
7. We will invoice the customer for the repair, which will then become part of your claim. The Invoice must be presented to the trucking claim department along with their claim form.
8. We suggest if the trucker does not pay within 30 days that you call and / or write the ICC making a formal complaint of poor service. Also advise **LAPLANTE** in writing for follow-up.
If damage can be repaired at the receiving point, follow Procedure 1, steps 1 through 4a. Repair the unit and make out a detailed invoice to the trucker showing labor hours, labor rate, materials used, and cost of materials.

Storage

In some cases it may necessary to store the compressor for extended periods of several months before placing the unit in operation. When this is required do the following:

- Cover and seal all machine openings to prevent the entrance of water and dirt.
- Cover all openings in open drip proof motors to prevent the entrance of rodents.
- If the storage conditions are below freezing, drain off the tank, traps, and attendant piping.
- We do not recommend outside storage.
- Cover with a waterproof tarpaulin that can easily be removed for in storage maintenance.
- While in storage, every two to three months rotate the compressor and motor by hand to prevent flat spots on the bearings that will lead to premature failure.
- At the end of the storage period, follow the uncrating and start-up procedures. If the unit has been stored for more than eighteen months you should contact **LAPLANTE** before restarting the compressor.



Appropriate use

As standard, **LAPLANTE** piston compressors are intended for the compression of ambient air. The air may not contain any aggressive or combustible mixtures.

The pressure chambers of the compressor are oil-lubricated. Therefore, the compressed air produced may only be used as breathing air or come into contact with food if it has been treated beforehand.



As standard this LAPLANTE piston compressor is not of an explosion-protected design and it may not be operated in areas subject to explosion hazards!



Symbols used

We have used the following symbols in this text to mark particularly important points:



The general warning sign indicates information concerning possible danger to operator and machine.



The lightning symbol indicates work which must exclusively be performed by skilled electricians.



The pointing hand indicates particularly important statements.



The spanner indicates maintenance work.



Danger is used to indicate the presence of a hazard, which will cause severe personal injury, death or substantial equipment and property damage if the warning is ignored.



Warning is used to indicate the presence of a hazard that can cause severe personal injury, death or substantial equipment and property damage if the warning is ignored.



Caution is used to indicate the presence of a hazard that will or can cause personal injury or equipment and property damage if the warning is ignored.



Notice is used to notify people of installation, operation, or maintenance of information that is important but not hazard related.

Symbols on the compressor

**Warning:**

Hot surfaces: Do not touch!

**Warning:**

The unit is operated by remote control, and might start without warning.

**Note:**

Instructions for the operating personnel must be read.

**Prohibited:**

Never open the valve before the air hose (connection to the compressed air network) is connected.

**Forbidden**

TO remove protective covering and safety devices

**Danger:**

Hot or noxious gases outlet: unbreathable

**Danger:**

High voltage disconnect power source before servicing



**Danger:
Spray injury!**

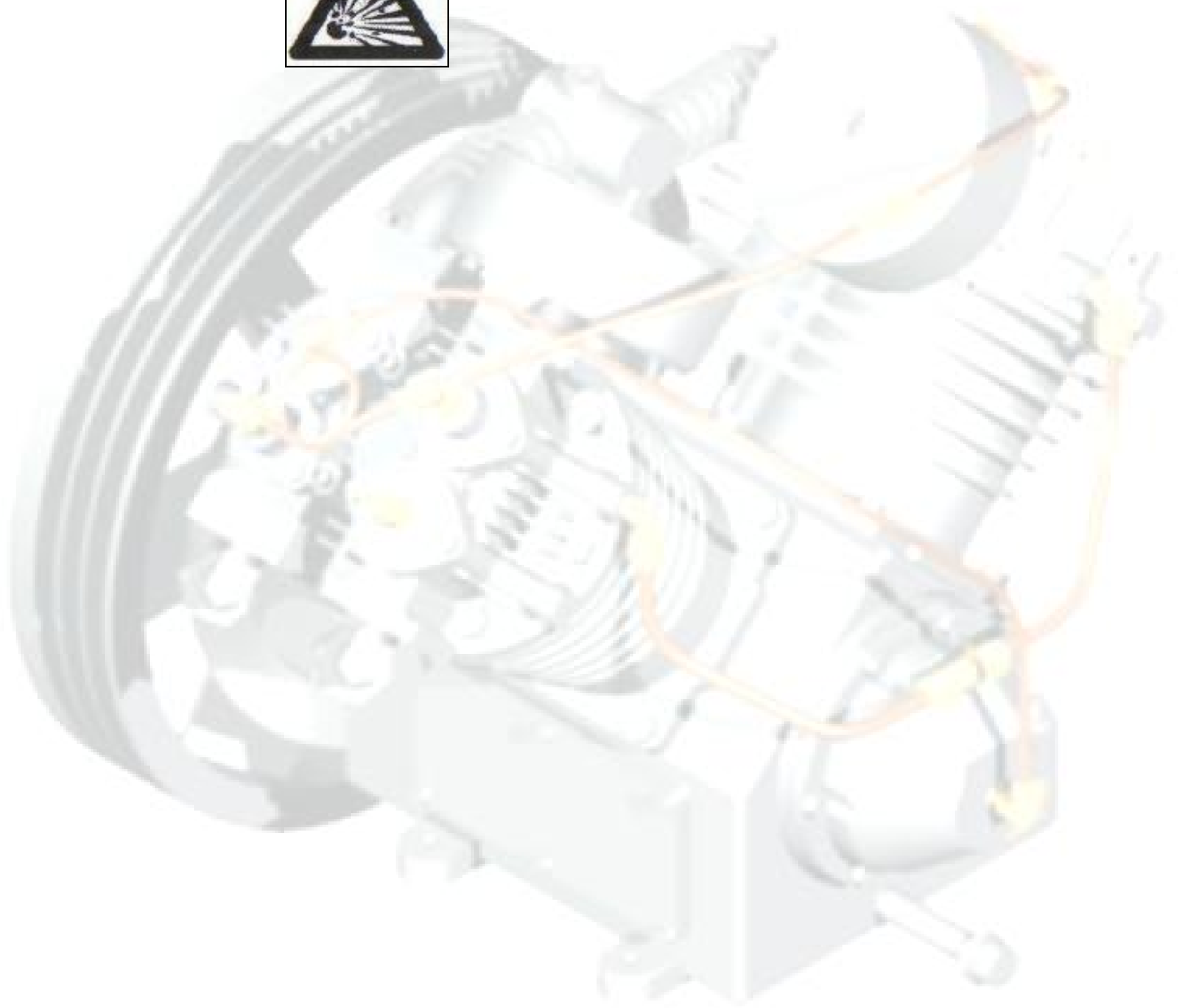

Safety Guide

Compressor Safety Precautions



An air compressor is a dynamic piece of machinery needing the same common sense safety precautions that should be observed with any operating machinery. Careless operation or maintenance is hazardous to personnel.



In addition to the obvious safety rules that should be followed with machinery, we recommend the following additional safety precautions.

1. Read and understand all instructions completely before operating this compressor.
2. Disengage power mains and disconnect power lines to the machine, if used, prior to attempting to work or perform maintenance on this unit.
3. Open tank discharge valve and relieve all pressure from tank and compressor lines. Do not attempt to remove any pressurized system parts without first relieving the pressure within the unit.
4. Do not attempt to service any part while the machine is in operation.
5. Do not operate the compressor at pressures in excess of its indicated rating on the compressor nameplate.
6. Do not operate the compressor at speeds in excess of its indicated rating on the compressor nameplate.
7. Do not remove guards, shields, or screens while the compressor is operating. If removed for maintenance replace before resuming operation.
8. Observe the delivery pressure gauge daily to be sure the automatic control system is operating within proper limits.
9. Periodically check all safety and relief devices for proper operation.
10. Do not play with compressed air. Pressurized air can cause serious injury or death to personnel.
11. Be sure that no tools, rags, or loose parts are left on the compressor or drive parts.

12. Do not use flammable solvents for cleaning parts.
13. Exercise cleanliness during maintenance and when making repairs.
Keep dirt away from parts and exposed openings by covering with a clean cloth or Kraft paper.
14. Install pressure relief valves in any isolatable piping in the plant system.
15. Do not operate the compressor in areas where there is the possibility of ingesting flammable or toxic gases.
16. Check pipe for any signs of wear or deterioration before each use and make certain that all connections are secure.
17. Observe the prescribed maintenance intervals.
18. Only use genuine **LAPLANTE** parts.
19. Only use **LAPLANTE** compressor oils and operating material recommended by **LAPLANTE**.
20. Strictly observe the effluent disposal laws of your local authority when disposing of condensate!



Make sure to investigate the code requirements to ensure compliance prior to operating the compressor.



The owner, lessor, or operator of this compressor is hereby notified and forewarned that any failure to observe these safety precautions may result in injury, death and/or property damage.



Package Outline Informations

SHEET 1 OF 1

TRADE SECRET—CONFIDENTIAL AND PROPRIETARY
 EXCLUSIVELY OWNED BY LAPLANTE COMPRESSOR, LTD.
 ANY COPYING, USE OR DISCLOSURE WITHOUT THE WRITTEN
 PERMISSION OF LAPLANTE COMPRESSOR, LTD. IS STRICTLY
 PROHIBITED. THIS MATERIAL IS PROTECTED UNDER
 TRADE SECRET AND UNFAIR COMPETITION LAWS. THE
 DISSEMINATION OF THIS INFORMATION IS PROHIBITED UNDER
 FEDERAL COPYRIGHT LAWS. VIOLATIONS MAY RESULT IN
 CIVIL AND CRIMINAL FINES AND PENALTIES.

Ø572

4-17.5X27
4 PLACES

(610)

(950)

(1830)

DISCHARGE PORT NPT 1/2" FEMALE

DRAIN PORT NPT 1/4" FEMALE

SPECIFICATIONS:

PUMP:

1. Type: LP205
2. Cylinders: 2
3. Bore: LP 4.13" / 105mm, HP 2.16" / 55mm
4. Stroke: 3.5" / 89mm
5. RPM: 600 Min / 1200 Max
6. Pump Flywheel: 17" / 430 mm
7. Groove of Flywheel: 2B

MOTOR:

1. Power: 7.5HP / 5.5KW
2. Voltages: 208 - 230V
3. Phase: 1 PH
4. Frequency: 60 HZ
5. AMPS: 33 ~ 30 A, SF.AMPS: 38 ~ 35A
6. RPM: 1760
7. Motor Pulley: 2BK90H-1 3/8" W/Bushing

Tank:

1. Tank: 80G / 302.8 Ltr
2. Max. Pressure: 200 PSI
3. Certification: ASME "U" Stamp

CONTROL:

1. Pressure Switch
2. Magnetic Starter

Rating CFM: At 125 PSI: 21
 At 150 PSI: 20
 At 175 PSI: 19.5

Rating ACFM: At 125 PSI: 20.37
 At 150 PSI: 19.4
 At 175 PSI: 18.9

STANDARD PACKAGE:

1. Single: 1 PC, Net Weight: 305 Kg / 673 LB
2. Packing: 1 PC, Gross Weight: 361 Kg / 795 LB
3. 20' Container: 16 PCS, 1 PC / 1 Crate
4. 40' Container: 32 PCS, 1 PC / 1 Crate

Address: 7092 Mississauga Road, Mississauga, ON L4V 1V5
 Telephone: (710) 466-0261
 E-mail: sales@laplante.com
 Web Site: www.Laplantecompressor.com

TITLE

V8071-205 Specifications

Exploded Drawing

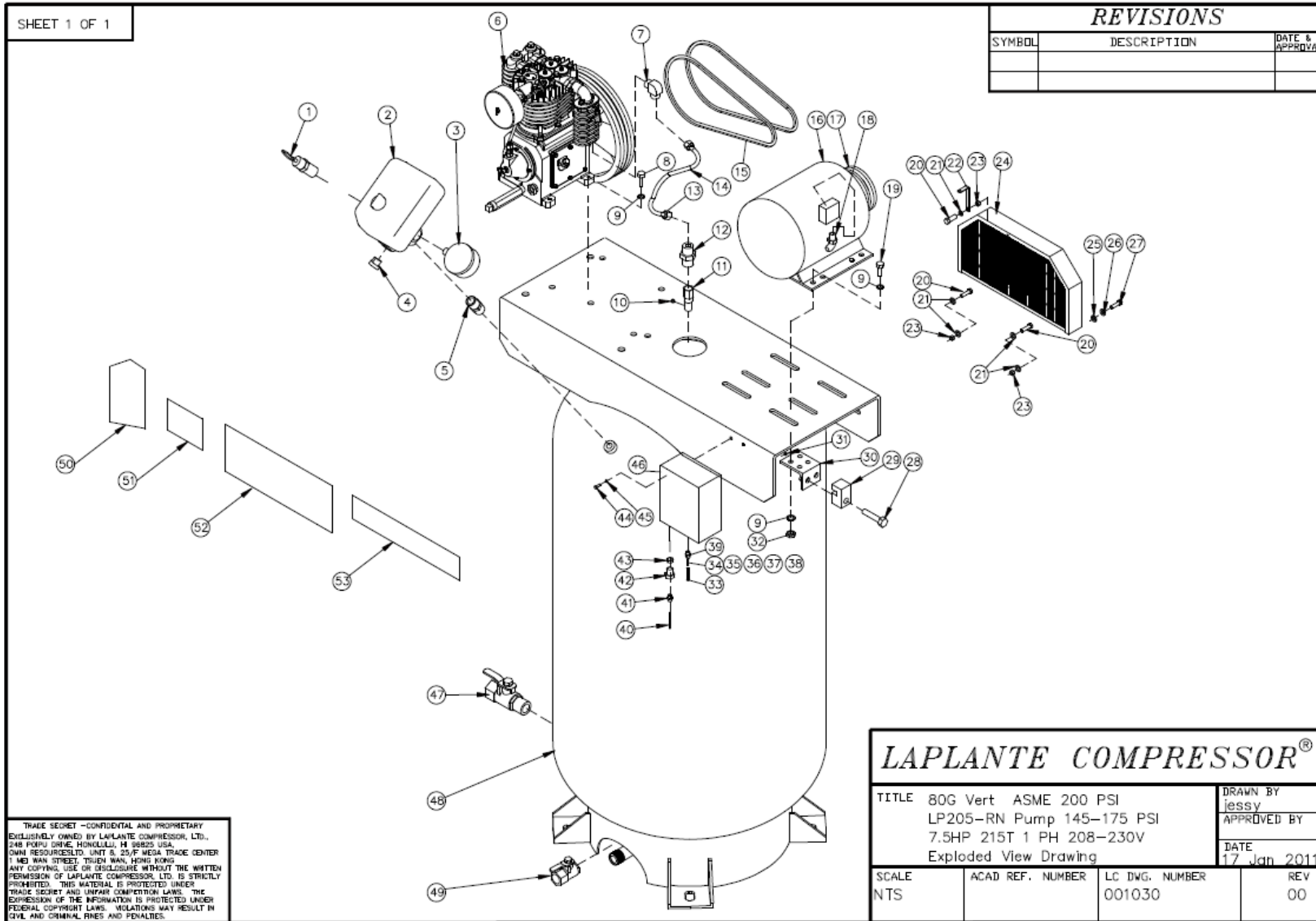

V8071-205 Bill of Material List**001030 Parts List**

Item	LAP#	Description	QTY
1	690008	Valve, Safety; ASME 200PSI 1/4M	1
2	340007	Pressure Switch; 140-175 PSI	1
3	350015	Gauge, Air; 300 PSI 2" 1/4M Left w/ oil	1
4	140100	Plug, Hex; 1/4M	1
5	640000	Nipple; Brass; 1/4M 1/4M	1
6	800052	Pump; LP205	1
7	640022	Elbow, 90Deg 3/4M 1-1/16"-12UN M	1
8	110261	Bolt, Hexhead; M10×50	4
9	130104	Washer, Flat; 10mm Large	8
10	140103	Plug, Hex; 1/8M	1
11	690024	Check Valve, Brass; 3/4F 3/4M 1/8F	1
12	640034	Fitting, 3/4M 1-1/16"-12UN M	1
13	120114	Nut, Compression; 1-1/16"-12UN	2
14	320028	Tube, Copper; Φ19mm O.D.X1	1
15	420028	V-Belt; B1956Li 77"	2
16	240024	Motor, 7.5HP 215T 1PH 208-230V TEFC 4P	1
17	713249	Pulley; 2BK90H- 1 3/8" w/ Bushing	1
18	290044	Elbow Connector, M27X2.0 /AD28.5	1
19	110288	Bolt, Hexhead; M10×35	4
20	110281	Bolt, Hexhead; M8×25	5
21	130103	Washer, Flat; 8mm Large	10
22	524022	Bracket, Belt Guard Top	1
23	120108	Nut, Nyloc; M8	5
24	520043	Belt Guard Assy, Wire Design	1
25	130118	Washer, Flat; 6mm Large	9
26	130105	Wahser, Lock 6 mm	9

27	110275	Bolt, Hexhead; M6×20	9
28	110267	Bolt, Hexhead; M10×100	1
29	390000	Tension Block	1
30	390001	Tension Plate	1
31	120115	Nut, Nyloc; M5	4
32	120109	Nut, Nyloc; M10	8
33	290040	Nylon Conduit WAY-PA6 AD 28.5G, Length 1050mm	1
34	290064	Wire Set; Starter	1
35	290070	R Type Terminal for Wire AWG6-6	5
36	290071	R Type Terminal for Wire AWG6-8	1
37	110291	Cross Pan Head Screw M4X12	3
38	120116	Nut, Nyloc; M4	2
39	290062	Quick Connector, M32X2.0	1
40	290013	Wire Set; Pressure Switch	1
41	290037	Cable Clamp M20X1.5	1
42	290048	Reducer, Nyloc M32/M20G	1
43	290059	Nut, Nyloc M32X1.5	1
44	110285	Screw, Hex Socket Head; M5X20	2
45	130116	Washer, Flat; 5mm	4
46	340023	Starter Assy, Magnetic	1
47	690014	Ball Valve, Brass; 3/4M 3/4F	1
48	330049	Tank; 80G VERT ASME 200 PSI	1
49	690009	Ball Valve, Brass; 1/4F 1/4F	1
50	190221	Tag for change the oil	1
51	191022	Nameplate	1
52	191025	Decal	1
53	191024	LOGO	1

Operating instructions

Industrial piston air compressors

Model: LP205 Series

7502 Mesa Road Houston, TX77028

Telephone: (713) 635-6331

E-mail: service@lapante.com

Web Site: www.lapantecompressor.com

 **LAPLANTE**
COMPRESSOR



Issue: 06/2010

Contents	Page
SECTION I	1
INTRODUCTION	1
UNPACKING AND HANDLING	2
APPROPRIATE USE	4
SYMBOLS USED	5
SYMBOLS USED	5
SYMBOLS ON THE COMPRESSOR	6
SAFETY GUIDE	8
SECTION II	1
INSTALLATION INSTRUCTION	1
TECHNICAL DATA	1
EXPLODE DRAWING	2
BILL OF MATERIAL LIST	3
INSPECTION	10
HEAD UNLOADER	12
CENTRIFUGAL UNLOADER	16
OPERATION	18
SECTION III	1
PARTS KITS	1
OVERHAUL KIT	1
RING SET	1
VALVE SET	1
GASKET SET	1
BOLT TORQUE CHART	2
DISASSEMBLE PUMP	3
ASSEMBLE PUMP	5
TROUBLESHOOTING	7
MAINTENANCE	7
GENERAL	7
SAFETY INFORMATION	8
CHECK OIL LEVEL	8
CHECK AND CLEAN COMPRESSOR VALVES	10
CHECK THE SAFETY VALVE	11
CHANGE OIL	14
CHECK AND CHANGE AIR FILTER	14
MAINTENANCE SCHEDULE	15
LIST OF MAINTENANCE AND SERVICE WORK	16

Introduction

These operating instructions form part of the machine and must be made available to the compressor operating personnel at all times. In order to receive maximum performance and long life from your compressor, the following instructions should carefully read and all points regarding installation and operation of the unit should be noted and observed .careful reading of this manual, prior to connecting anything to the motor or compressor, will pay dividends in long term trouble-free operation.



Unpacking and Handling



Occasionally damage will occur during shipping. Be sure to carefully inspect the unit before unpacking and after unpacking **BEFORE** you sign the receiver. If any has occurred, document it with the trucking firm immediately. Contact your LAPLANTE representative for assistance.

To move your compressor to its installation site we recommend that you leave the unit on its shipping skid as long as possible. The forks should be extended the width of the compressor and padding should be placed between the compressor and the fork truck boom.

If it is necessary to lift the compressor with a crane, we recommend the use of spreader bar and chains. The spreader bar should be greater than the width of the compressor and padding placed on the edges to prevent chain damage.



DO NOT UTILIZE THE PUMP OR DRIVE AS A LIFT POINT

Procedure for Handling Damaged Shipments

1. The customer, at the receiving point, **MUST** inspect each shipment for damage.
2. If the shipment is damaged, the customer should so note it on the freight bill.
3. The customer should request an inspector from the freight company to inspect the equipment immediately. It is best to send a confirming letter with the following information:
 - a. Freight bill number.
 - b. Date delivered - shipper's name & address.
 - c. Description of item(s) damaged.
 - d. Description of damage (a Polaroid picture if possible).
 - e. A copy of your invoice for the equipment.
4. After inspection, (before the inspector leaves):
 - a. Get a copy of the inspection report.
 - b. Request the unit be shipped back "free astray".
 - c. Request a credit for the original freight bill.
5. Call the factory and:
 - a. Get a Return Material Authorization (RMA number).
 - b. Give a purchase order for repair. The purchase order should refer to the item and trucker claim.



6. We will accept the shipment back, repair (under normal conditions) and return it within (7) seven working days.
7. We will invoice the customer for the repair, which will then become part of your claim. The Invoice must be presented to the trucking claim department along with their claim form.
8. We suggest if the trucker does not pay within 30 days that you call and / or write the ICC making a formal complaint of poor service. Also advise **LAPLANTE** in writing for follow-up.
If damage can be repaired at the receiving point, follow Procedure 1, steps 1 through 4a. Repair the unit and make out a detailed invoice to the trucker showing labor hours, labor rate, materials used, and cost of materials.

Storage

In some cases it may necessary to store the compressor for extended periods of several months before placing the unit in operation. When this is required do the following:

- Cover and seal all machine openings to prevent the entrance of water and dirt.
- Cover all openings in open drip proof motors to prevent the entrance of rodents.
- If the storage conditions are below freezing, drain off the tank, traps, and attendant piping.
- We do not recommend outside storage.
- Cover with a waterproof tarpaulin that can easily be removed for in storage maintenance.
- While in storage, every two to three months rotate the compressor and motor by hand to prevent flat spots on the bearings that will lead to premature failure.
- At the end of the storage period, follow the uncrating and start-up procedures. If the unit has been stored for more than eighteen months you should contact **LAPLANTE** before restarting the compressor.



Appropriate use

As standard, **LAPLANTE** piston compressors are intended for the compression of ambient air. The air may not contain any aggressive or combustible mixtures.

The pressure chambers of the compressor are oil-lubricated. Therefore, the compressed air produced may only be used as breathing air or come into contact with food if it has been treated beforehand.



As standard this LAPLANTE piston compressor is not of an explosion-protected design and it may not be operated in areas subject to explosion hazards!



Symbols used

We have used the following symbols in this text to mark particularly important points:



The general warning sign indicates information concerning possible danger to operator and machine.

The lightning symbol indicates work which must exclusively be performed by skilled electricians.

The pointing hand indicates particularly important statements.

The spanner indicates maintenance work.



Danger is used to indicate the presence of a hazard, which will cause severe personal injury, death or substantial equipment and property damage if the warning is ignored.



Warning is used to indicate the presence of a hazard that can cause severe personal injury, death or substantial equipment and property damage if the warning is ignored.



Caution is used to indicate the presence of a hazard that will or can cause personal injury or equipment and property damage if the warning is ignored.



Notice is used to notify people of installation, operation, or maintenance of information that is important but not hazard related.

Symbols on the compressor



Warning:

Hot surfaces: Do not touch!



Warning:

The unit is operated by remote control, and might start without warning.



Note:

Instructions for the operating personnel must be read.



Prohibited:

Never open the valve before the air hose (connection to the compressed air network) is connected.



Forbidden

TO remove protective covering and safety devices



Danger:

Hot or noxious gases outlet: unbreathable



Danger:

High voltage disconnect power source before servicing



**Danger:
Spray injury!**

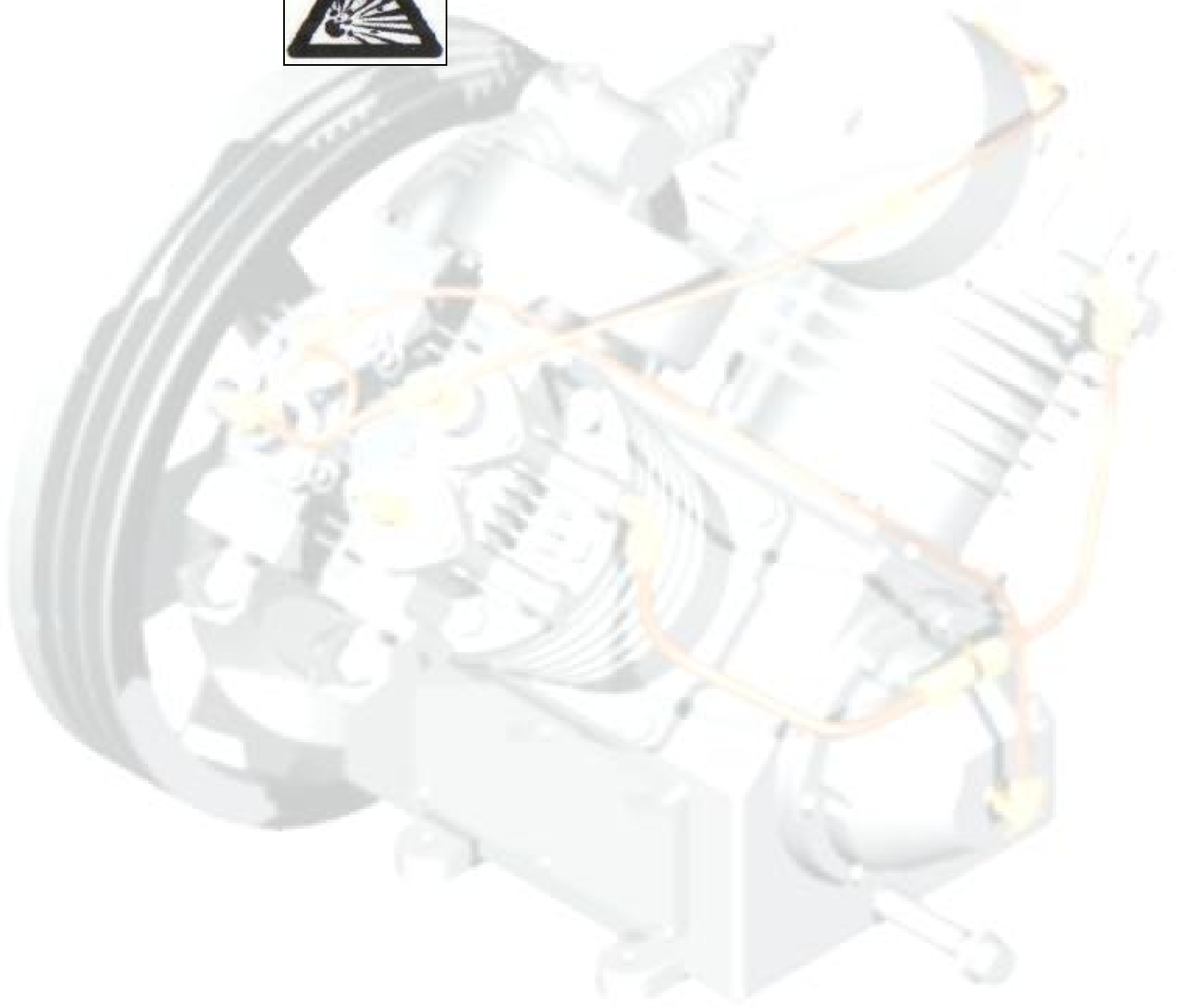

Safety Guide

Compressor Safety Precautions



An air compressor is a dynamic piece of machinery needing the same common sense safety precautions that should be observed with any operating machinery. Careless operation or maintenance is hazardous to personnel.



In addition to the obvious safety rules that should be followed with machinery, we recommend the following additional safety precautions.

1. Read and understand all instructions completely before operating this compressor.
2. Disengage power mains and disconnect power lines to the machine, if used, prior to attempting to work or perform maintenance on this unit.
3. Open tank discharge valve and relieve all pressure from tank and compressor lines. Do not attempt to remove any pressurized system parts without first relieving the pressure within the unit.
4. Do not attempt to service any part while the machine is in operation.
5. Do not operate the compressor at pressures in excess of its indicated rating on the compressor nameplate.
6. Do not operate the compressor at speeds in excess of its indicated rating on the compressor nameplate.
7. Do not remove guards, shields, or screens while the compressor is operating. If removed for maintenance replace before resuming operation.
8. Observe the delivery pressure gauge daily to be sure the automatic control system is operating within proper limits.
9. Periodically check all safety and relief devices for proper operation.
10. Do not play with compressed air. Pressurized air can cause serious injury or death to personnel.
11. Be sure that no tools, rags, or loose parts are left on the compressor or drive parts.

12. Do not use flammable solvents for cleaning parts.
13. Exercise cleanliness during maintenance and when making repairs.
Keep dirt away from parts and exposed openings by covering with a clean cloth or Kraft paper.
14. Install pressure relief valves in any isolatable piping in the plant system.
15. Do not operate the compressor in areas where there is the possibility of ingesting flammable or toxic gases.
16. Check pipe for any signs of wear or deterioration before each use and make certain that all connections are secure.
17. Observe the prescribed maintenance intervals.
18. Only use genuine **LAPLANTE** parts.
19. Only use **LAPLANTE** compressor oils and operating material recommended by **LAPLANTE**.
20. Strictly observe the effluent disposal laws of your local authority when disposing of condensate!



Make sure to investigate the code requirements to ensure compliance prior to operating the compressor.



The owner, lessor, or operator of this compressor is hereby notified and forewarned that any failure to observe these safety precautions may result in injury, death and/or property damage.



SHEET 1 OF 1

TRADE SECRET - CONFIDENTIAL AND PROPRIETARY. EXCLUSIVELY OWNED BY LAPLANTE COMPRESSOR, LTD. ANY COPYING, USE OR DISCLOSURE WITHOUT THE WRITTEN PERMISSION OF LAPLANTE COMPRESSOR, LTD. IS STRICTLY PROHIBITED. THIS MATERIAL IS PROTECTED UNDER TRADE SECRET AND UNFAIR COMPETITION LAWS. THE EXPRESSION OF THE INFORMATION IS PROTECTED UNDER FEDERAL COPYRIGHT LAWS. VIOLATIONS MAY RESULT IN CIVIL AND CRIMINAL FINES AND PENALTIES.

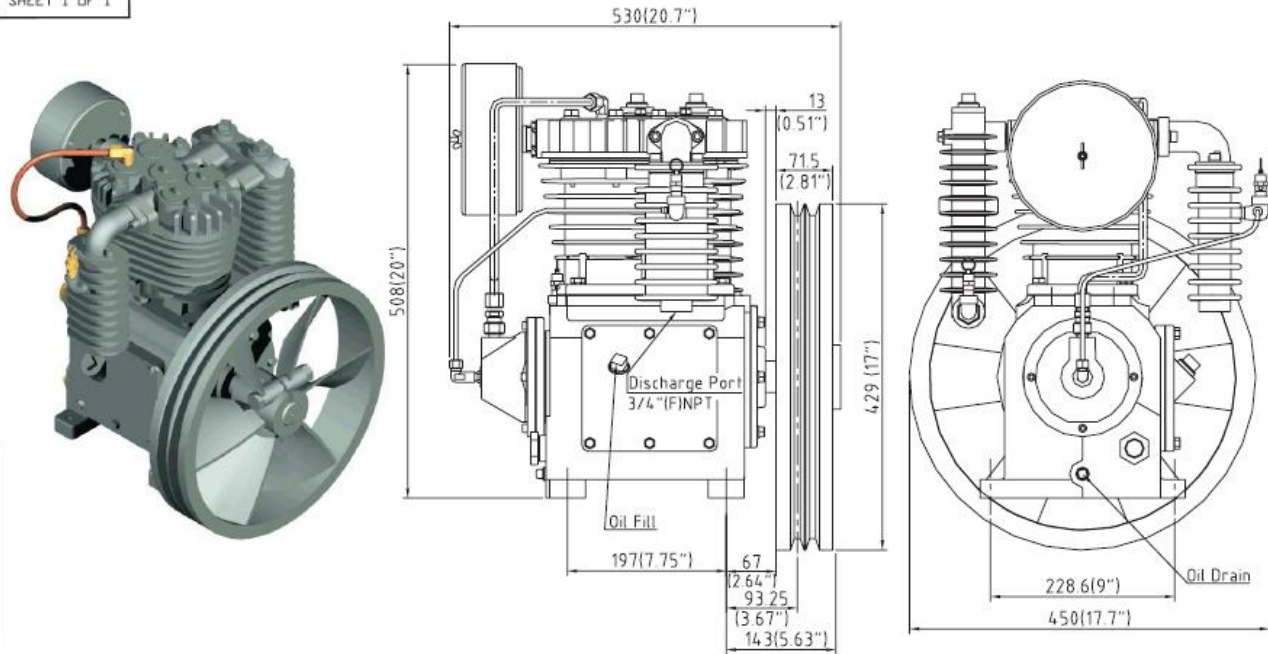

Specification:

- Power Range: 5~7.5HP/4~6.1Kw
- Maximum Pressure: 175Psi/12Bar
- Cylinders: 2
- Bore of LP: 4.13"/105mm
- Bore of HP: 2.16"/55mm
- Stroke: 3.5"/89mm
- RPM: 600~1200
- Flywheel Dia./Groove: 17"/429mm/2B

Features:

- Cast Iron Crankcase
- Cast Iron Cylinder
- Cast Iron Cylinder Head
- Ductile Iron Crankshaft
- Ductile Iron Conn. Rod
- Centrifugal Unloader Standard
- Head Unloader Optional
- Bronze Bushing Wrist Pin
- Babbitt Bearings Crankshaft
- Ball Main Bearings
- Steel Breather and Brass Sight Glass
- Power Coated Steel Filter Silencer
- Filled with DAB 150 Lubricant
- Synthetic Lubricant as Optional

Standard Package:

- Single : 1 Pcs,Weight:225B/102Kg
- Crate : 10 Pcs,Weight:2340LB/1060Kg
- 20' Container : 144 Pcs
- 40' Container : 212 Pcs

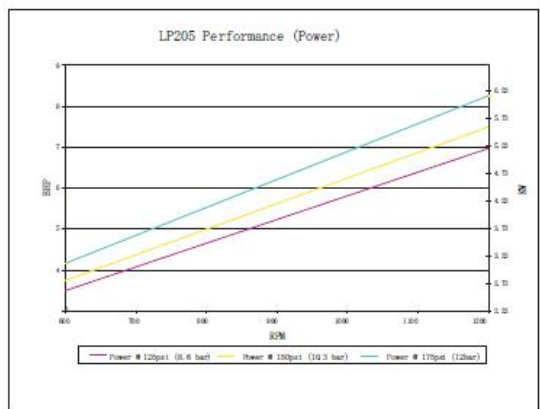
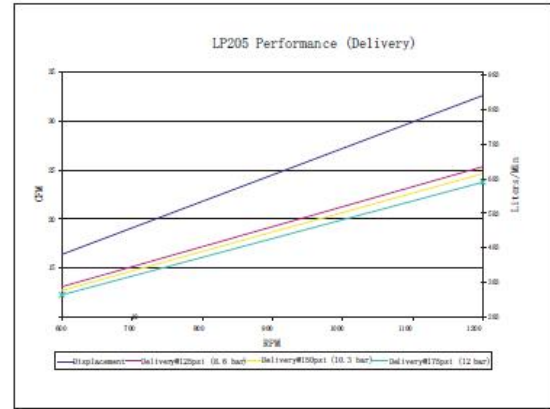

LAPLANTE COMPRESSOR
 Address: 7932 West Road Houston, TX 77033
 Telephone: (713) 659-6281
 Email: sales@laplante.com
 Web Site: www.laplantecompressor.com

TITLE
LP205 Specifications



LP205 Exploded Drawing

SHEET 1 OF 1		<p style="text-align: center;">REVISIONS</p> <table border="1" style="width: 100%; border-collapse: collapse;"> <thead> <tr> <th style="width: 15%;">SYMBOL</th> <th style="width: 60%;">DESCRIPTION</th> <th style="width: 25%;">DATE & APPROVAL</th> </tr> </thead> <tbody> <tr> <td> </td> <td> </td> <td> </td> </tr> <tr> <td> </td> <td> </td> <td> </td> </tr> </tbody> </table>	SYMBOL	DESCRIPTION	DATE & APPROVAL						
SYMBOL	DESCRIPTION	DATE & APPROVAL									

<p style="text-align: center;">LAPLANTE COMPRESSOR®</p>			
<p>TITLE AIR COMPRESSOR CAST IRON HOUSING/CYLINDER EXPLODED VIEW DRAWING</p>		<p>DRAWN BY APPROVED BY DATE</p>	
SCALE NTS	ACAD REF. NUMBER LP205	LC Dwg. NUMBER LP205	REV 00

TRADE SECRET - CONFIDENTIAL AND PROPRIETARY EXCLUSIVELY OWNED BY LAPLANTE COMPRESSOR, LTD., 248 POPU DRIVE, WONGKULLU, HI 98025 USA. OWN RESOURCES/LTD. UNIT 6, 25/F MEGA TRADE CENTER 1, HO WAH STREET, TSIEN WAN, HONG KONG. ANY COPYING, USE OR DISCLOSURE WITHOUT THE WRITTEN PERMISSION OF LAPLANTE COMPRESSOR, LTD. IS STRICTLY PROHIBITED. THIS MATERIAL IS PROTECTED UNDER TRADE SECRET AND UNFAIR COMPETITION LAWS. THE EXPRESSION OF THE INFORMATION IS PROTECTED UNDER FEDERAL COPYRIGHT LAWS. VIOLATIONS MAY RESULT IN CIVIL AND CRIMINAL FINES AND PENALTIES.

LP205 Bill of material list

LP205 Parts List							
Item	LAP#	Description	QTY	Item	LAP#	Description	QTY
1	080029	Key Flywheel	1	44	160003	Elbow Street 90 Degrees 1/4"	2
2	713001	Flywheel 17" 2B	1	45	722007	Valve Safety 200 PSI ASME	1
3	110117	Capscrew Hex M8X20	19	46	070167	Gasket Aftercooler	2
4	070201	Gasket Copper	24	47	706002	Elbow Aftercooler	1
5	060068	Seal -Shaft	1	48	110106	Capscrew SKT Head M8 X 25	4
6	701000	Front Bearing Carrier	1	49	070161	Gasket Cylinder Head	1
7	050115	Bearing Cap	2	50	130058	Lockwasher 8	8
8	050170	Bearing Front	1	51	110111	Capscrew Hex M12 X 70	8
9	709000	Crankshaft	1	52	710000	Head Cylinder	1
10	050172	Bearing Rear	1	53	070169	Gasket Intercooler	2
11	070163	Gasket Front Cap	1	54	160002	Bushing Reducing 3/4"M X 1/4"F NPT	1
12	070164	Gasket Side Cover	1	55	722005	Valve Safety 75 Psi	1
13	160004	Plug Oil Fill-3/4" NPT	4	56	706000	Intercooler	1
14	020146	Cover Crankcase Side	1	57	110105	Capscrew Hex M8X85	4
15	708000	Crankcase	1	58	110102	Capscrew SKT Head M10x45	4
15	090095	Shim .015 Brg Adjustment	1	59	130060	Lockwasher M10	4
15	090094	Shim .010 Brg Adjustment	1	60	705003	Dipper Oil	2
16	090093	Shim .005 Brg Adjustment	1	61	100101	Dowel alignment	4
17	070172	Gasket Rear Cap	1	62	050122	Insert Rod-Bearing Half	4
18	731005	Oil Level Sight Glass; Copper	1	63	705107	Rod Connecting steel w/Needle Bearing	2
19	160005	Plug Oil Drain-3/8" NPT	1	64	050121	Needle Bearing	2
20	701029	Cap Rear	1	65	120060	Nut Hex-M16	1
21	728000	Weight Unloader	2	66	130057	Lockwasher M16	1
22	100100	Pin - Hinge	2	67	110108	Capscrew Hex M16 X 80	1
23	728002	Holder Unloader	1	68	720002	Piston HP	1
24	723003	Spring Unloader	1	69	729006	Wristpin HP Piston	1
25	728003	Plunge Unloader	1	70	719088	Piston Rings Set HP	1
26	070166	Gasket Unloader Cover	1	71	200100	Snapping Internal	4
27	728004	Centrifugal Unloader Adapter Plate	1	72	729000	Wristpin- LP Piston	1
28	110104	Capscrew Skt HD M6X20	4	73	720000	Piston LP	1
29	704000	Elbow Valve and Unloader	1	74	719064	Piston Ring Set LP	1
30	725243	Cooper Tube	1	75	727002	Valve Assy HP/LP Discharge	2
31	120058	Nut Adjustment Lock	1	76	727001	Valve Assembly-HP Inlet	1
32	703011	Breather	1	77	727004	Spacer Discharge Valve	2
33	718006	Straight Breather Connector	1	78	727135	Retainer Discharge Valve	3
34	703017	Breather Tube	1	79	070202	Copper Valve Seat Gasket	5
35	718015	Breather Elbow	1	80	727000	Valve Assembly-LP Inlet	2
36	712005	Filter Inlet Assembly	1	81	727003	Spacer Inlet Valve	3
37	712006	Filter Element	1	82	727134	Retainer Inlet Valve	1
38	070203	Gasket Copper	6	83	727300	Retainer Inlet Valve	1
39	110107	Capscrew Hex M10 X 25	6	84	070170	Gasket Valve Cover	3
40	070162	Gasket Cylinder To Crankcase	1	85	727136	Cover Valve	3
41	711000	Cylinder	1				
42	706004	Aftercooler	1				
43	718200	Tube Str. Connector 1/8(M)XM12	1				

LP205-3 Exploded Drawing

SHEET 1 OF 1

REVISIONS

SYMBOL	DESCRIPTION	DATE & APPROVAL

TRADE SECRET - CONFIDENTIAL AND PROPRIETARY EXCLUSIVELY OWNED BY LAPLANTE COMPRESSOR, LTD., 248 POKPU DRIVE, HONGKONG, HONG KONG. OWN RESOURCES/UNIT 0, 25/F MEGA TRADE CENTER 1, HEI WAN STREET, TSIM SHAN, HONG KONG. ANY COPYING, USE OR DISCLOSURE WITHOUT THE WRITTEN PERMISSION OF LAPLANTE COMPRESSOR, LTD. IS STRICTLY PROHIBITED. THIS MATERIAL IS PROTECTED UNDER TRADE SECRET AND UNFAIR COMPETITION LAWS. THE EXPRESSION OF THE INFORMATION IS PROTECTED UNDER FEDERAL COPYRIGHT LAWS. VIOLATIONS MAY RESULT IN CIVIL AND CRIMINAL FINES AND PENALTIES.

LAPLANTE COMPRESSOR®

TITLE		DRAWN BY	
AIR COMPRESSOR CAST IRON HOUSING/CYLINDER EXPLODED VIEW DRAWING		APPROVED BY	
SCALE		DATE	
NTS	ACAD REF. NUMBER LP205-3	LC DWG. NUMBER LP205	REV 00

LP205-3 Bill of Material List

LP205-3 Parts List							
Item	LAP#	Description	QTY	Item	LAP#	Description	QTY
1	080029	Key Flywheel	1	44	160003	Elbow Street 90 Degrees 1/4"	2
2	713001	Flywheel 17" 2B	1	45	722007	Valve Safety 200 PSI ASME	1
3	110117	Capscrew Hex M8X20	19	46	070167	Gasket Aftercooler	2
4	070201	Gasket Copper	24	47	706002	Elbow Aftercooler	1
5	060068	Seal -Shaft	1	48	110106	Capscrew SKT Head M8 X 25	4
6	701000	Front Bearing Carrier	1	49	070161	Gasket Cylinder Head	1
7	050115	Bearing Cap	2	50	130058	Lockwasher 8	8
8	050170	Bearing Front	1	51	110111	Capscrew Hex M12 X 70	8
9	709000	Crankshaft	1	52	710000	Head Cylinder	1
10	050172	Bearing Rear	1	53	070169	Gasket Intercooler	2
11	070163	Gasket Front Cap	1	54	160002	Bushing Reducing 3/4"M X 1/4"F NPT	1
12	070164	Gasket Side Cover	1	55	722005	Valve Safety 75 Psi	1
13	160004	Plug Oil Fill-3/4" NPT	4	56	706000	Intercooler	1
14	020146	Cover Crankcase Side	1	57	110105	Capscrew Hex M8X85	4
15	708000	Crankcase	1	58	110102	Capscrew SKT Head M10x45	4
15	090095	Shim .015 Brg Adjustment	1	59	130060	Lockwasher M10	4
15	090094	Shim .010 Brg Adjustment	1	60	705003	Dipper Oil	2
16	090093	Shim .005 Brg Adjustment	1	61	100101	Dowel alignment	4
17	070172	Gasket Rear Cap	1	62	050122	Insert Rod-Bearing Half	4
18	731005	Oil Level Sight Glass; Copper	1	63	705107	Rod Connecting steel w/Needle Bearing	2
19	160005	Plug Oil Drain-3/8" NPT	1	64	050121	Needle Bearing	2
20	701029	Cap Rear	1	65	120060	Nut Hex-M16	1
21	728000	Weight Unloader	2	66	130057	Lockwasher M16	1
22	100100	Pin - Hinge	2	67	110108	Capscrew Hex M16 X 80	1
23	728002	Holder Unloader	1	68	720002	Piston HP	1
24	723003	Spring Unloader	1	69	729006	Wristpin HP Piston	1
25	728003	Plunge Unloader	1	70	719088	Piston Ring Set HP	1
26	070166	Gasket Unloader Cover	1	71	200100	Snapping Internal	4
27	728004	Centrifugal Unloader Adapter Plate	1	72	729000	Wristpin- LP Piston	1
28	110104	Capscrew Skt HD M6X20	4	73	720000	Piston LP	1
29	704000	Elbow Valve and Unloader	1	74	719064	Piston Ring Set LP	1
30	725243	Cooper Tube	1	75	727002	Valve Assy HP/LP Discharge	2
31	120058	Nut Adjustment Lock	1	76	727001	Valve Assembly-HP Inlet	1
32	703011	Breather	1	77	727004	Spacer Discharge Valve	2
33	718006	Straight Breather Connector	1	78	727135	Retainer Discharge Valve	3
34	703017	Breather Tube	1	79	070202	Copper Valve Seat Gasket	5
35	718015	Breather Elbow	1	80	727000	Valve Assembly-LP Inlet	2
36	712005	Filter Inlet Assembly	1	81	727003	Spacer Inlet Valve	3
37	712006	Filter Element	1	82	727134	Retainer Inlet Valve	1
38	070203	Gasket Copper	6	83	727300	Retainer Inlet Valve	1
39	110107	Capscrew Hex M10 X 25	6	84	070170	Gasket Valve Cover	3
40	070162	Gasket Cylinder To Crankcase	1	85	727136	Cover Valve	3
41	711000	Cylinder	1	86	718102	Oil Drain Pipe 3"	1
42	706004	Aftercooler	1				
43	718200	Tube Str. Connector 1/8(M)XM12	1				

LP205-6 Exploded Drawing

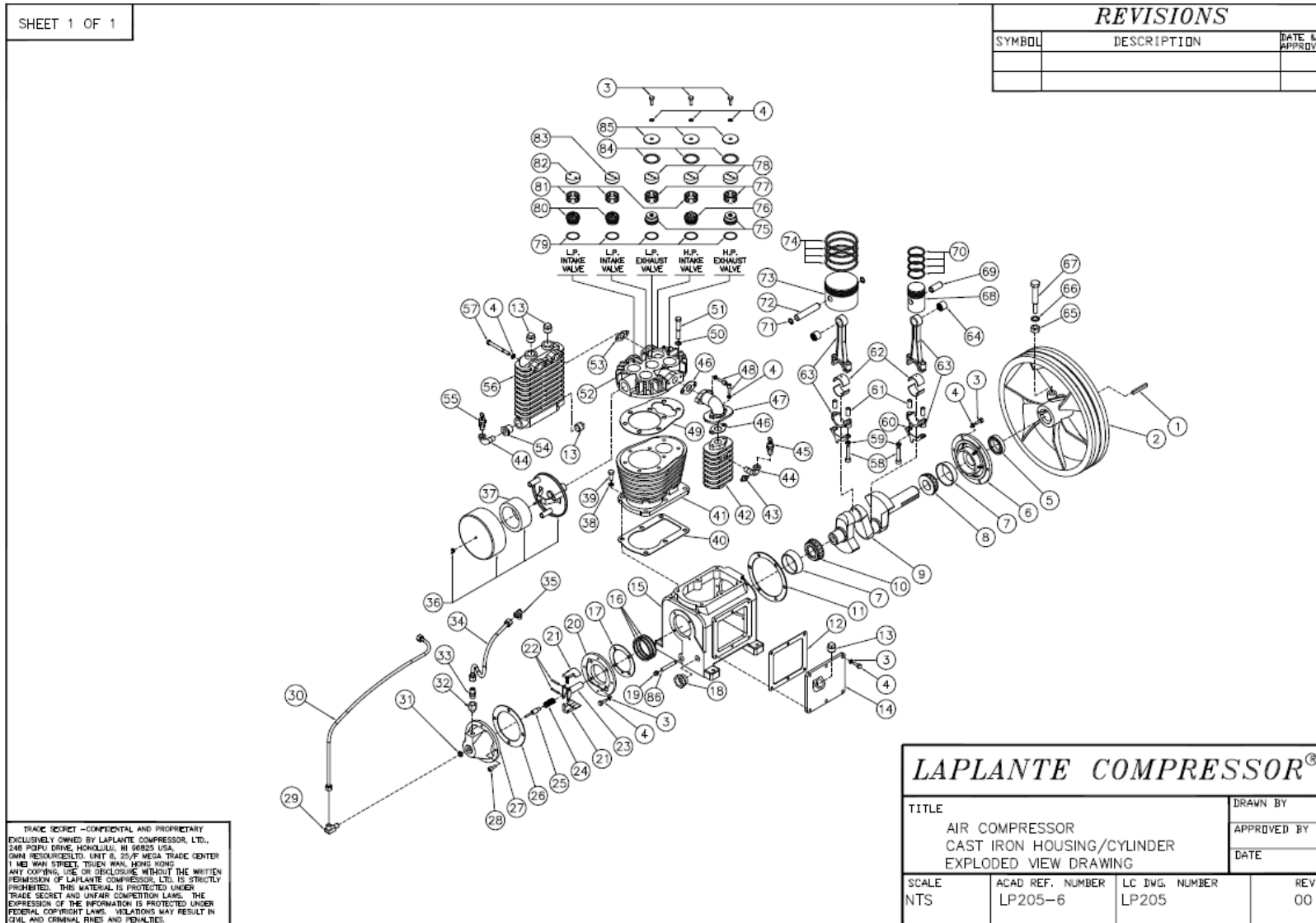

LP205-3 Bill of Material List

LP205-6 Parts List							
Item	LAP#	Description	QTY	Item	LAP#	Description	QTY
1	080029	Key Flywheel	1	44	160003	Elbow Street 90 Degrees 1/4"	2
2	713001	Flywheel 17" 2B	1	45	722007	Valve Safety 200 PSI ASME	1
3	110117	Capscrew Hex M8X20	19	46	070167	Gasket Aftercooler	2
4	070201	Gasket Copper	24	47	706002	Elbow Aftercooler	1
5	060068	Seal -Shaft	1	48	110106	Capscrew SKT Head M8 X 25	4
6	701000	Front Bearing Carrier	1	49	070161	Gasket Cylinder Head	1
7	050115	Bearing Cap	2	50	130058	Lockwasher 8	8
8	050170	Bearing Front	1	51	110111	Capscrew Hex M12 X 70	8
9	709000	Crankshaft	1	52	710000	Head Cylinder	1
10	050172	Bearing Rear	1	53	070169	Gasket Intercooler	2
11	070163	Gasket Front Cap	1	54	160002	Bushing Reducing 3/4"M X 1/4"F NPT	1
12	070164	Gasket Side Cover	1	55	722005	Valve Safety 75 Psi	1
13	160004	Plug Oil Fill-3/4" NPT	4	56	706000	Intercooler	1
14	020146	Cover Crankcase Side	1	57	110105	Capscrew Hex M8X85	4
15	708000	Crankcase	1	58	110102	Capscrew SKT Head M10x45	4
15	090095	Shim .015 Brg Adjustment	1	59	130060	Lockwasher M10	4
15	090094	Shim .010 Brg Adjustment	1	60	705003	Dipper Oil	2
16	090093	Shim .005 Brg Adjustment	1	61	100101	Dowel alignment	4
17	070172	Gasket Rear Cap	1	62	050122	Insert Rod-Bearing Half	4
18	731005	Oil Level Sight Glass; Copper	1	63	705107	Rod Connecting steel w/Needle Bearing	2
19	160005	Plug Oil Drain-3/8" NPT	1	64	050121	Needle Bearing	2
20	701029	Cap Rear	1	65	120060	Nut Hex-M16	1
21	728000	Weight Unloader	2	66	130057	Lockwasher M16	1
22	100100	Pin - Hinge	2	67	110108	Capscrew Hex M16 X 80	1
23	728002	Holder Unloader	1	68	720002	Piston-HP	1
24	723003	Spring Unloader	1	69	729006	Wristpin HP Piston	1
25	728003	Plunge Unloader	1	70	719088	Piston Ring Set HP	1
26	070166	Gasket Unloader Cover	1	71	200100	Snpring Internal	4
27	728004	Centrifugal Unloader Adapter Plate	1	72	729000	Wristpin- LP Piston	1
28	110104	Capscrew Skt HD M6X20	4	73	720000	Piston LP	1
29	704000	Elbow Valve and Unloader	1	74	719064	Piston Ring Set LP	1
30	725243	Cooper Tube	1	75	727002	Valve Assy HP/LP Discharge	2
31	120058	Nut Adjustment Lock	1	76	727001	Valve Assembly-HP Inlet	1
32	703011	Breather	1	77	727004	Spacer Discharge Valve	2
33	718006	Straight Breather Connector	1	78	727135	Retainer Discharge Valve	3
34	703017	Breather Tube	1	79	070202	Copper Valve Seat Gasket	5
35	718015	Breather Elbow	1	80	727000	Valve Assembly-LP Inlet	2
36	712005	Filter Inlet Assembly	1	81	727003	Spacer Inlet Valve	3
37	712006	Filter Element	1	82	727134	Retainer Inlet Valve	1
38	070203	Gasket Copper	6	83	727300	Retainer Inlet Valve	1
39	110107	Capscrew Hex M10 X 25	6	84	070170	Gasket Valve Cover	3
40	070162	Gasket Cylinder To Crankcase	1	85	727136	Cover Valve	3
41	711000	Cylinder	1	86	718104	Oil Drain Pipe 6"	1
42	706004	Aftercooler	1				
43	718200	Tube Str. Connector 1/8(M)XM12	1				

LP205-H Exploded Drawing

SHEET 1 OF 1		<p style="text-align: center;">REVISIONS</p> <table border="1" style="width: 100%; border-collapse: collapse;"> <thead> <tr> <th style="width: 15%;">SYMBOL</th> <th style="width: 55%;">DESCRIPTION</th> <th style="width: 30%;">DATE & APPROVAL</th> </tr> </thead> <tbody> <tr> <td> </td> <td> </td> <td> </td> </tr> <tr> <td> </td> <td> </td> <td> </td> </tr> </tbody> </table>	SYMBOL	DESCRIPTION	DATE & APPROVAL						
SYMBOL	DESCRIPTION	DATE & APPROVAL									

<p>LAPLANTE COMPRESSOR®</p>			
<p>TITLE AIR COMPRESSOR CAST IRON HOUSING/CYLINDER EXPLODED VIEW DRAWING</p>		<p>DRAWN BY APPROVED BY DATE</p>	
SCALE NTS	ACAD REF. NUMBER LP205-H	LC IMG. NUMBER LP205	REV 00

TRADE SECRET - CONFIDENTIAL AND PROPRIETARY EXCLUSIVELY OWNED BY LAPLANTE COMPRESSOR, LTD., 248 POPPU DRIVE, HONOLULU, HI 96825 USA. QMNI RESOURCES/LTD. UNIT 6, 25/F MEGA TRADE CENTER 1, HUI WAN STREET, TSIEN WAN, HONG KONG. ANY COPYING, USE OR DISCLOSURE WITHOUT THE WRITTEN PERMISSION OF LAPLANTE COMPRESSOR, LTD. IS STRICTLY PROHIBITED. THIS MATERIAL IS PROTECTED UNDER TRADE SECRET AND UNFAIR COMPETITION LAWS. THE EXPRESSION OF THE INFORMATION IS PROTECTED UNDER FEDERAL COPYRIGHT LAWS. VIOLATIONS MAY RESULT IN CIVIL AND CRIMINAL FINES AND PENALTIES.

LP205-H Bill of Material List

LP205-H Parts List							
Item	LAP#	Description	QTY	Item	LAP#	Description	QTY
1	080029	Key Flywheel	1	52	710000	Head Cylinder	1
2	713001	Flywheel 17" 2B	1	53	070169	Gasket Intercooler	2
3	110117	Capscrew Hex M8X20	18	54	160002	Bushing Reducing 3/4"M X 1/4"F NPT	1
4	070201	Gasket Copper	23	55	722005	Valve Safety 75 Psi	1
5	060068	Seal -Shaft	1	56	706000	Intercooler	1
6	701000	Front Bearing Carrier	1	57	110105	Capscrew Hex M8X85	4
7	050115	Bearing Cap	2	58	110102	Capscrew SKT Head M10x45	4
8	050170	Bearing Front	1	59	130060	Lockwasher M10	4
9	709000	Crankshaft	1	60	705003	Dipper Oil	2
10	050172	Bearing Rear	1	61	100101	Dowel alignment	4
11	070163	Gasket Front Cap	1	62	050122	Insert Rod-Bearing Half	4
12	070164	Gasket Side Cover	1	63	705107	Rod Connecting steel w/Needle Bearing	2
13	160004	Plug Oil Fill-3/4" NPT	4	64	050121	Needle Bearing	2
14	020146	Cover Crankcase Side	1	65	120060	Nut Hex-M16	1
15	708000	Crankcase	1	66	130057	Lockwasher M16	1
15	090095	Shim .015 Brg Adjustment	1	67	110108	Capscrew Hex M16 X80	1
15	090094	Shim .010 Brg Adjustment	1	68	720002	Piston HP	1
16	090093	Shim .005 Brg Adjustment	1	69	729006	Wristpin HP Piston	1
17	070172	Gasket Rear Cap	1	70	719088	Piston Ring Set LP	1
18	731005	Oil Level Sight Glass; Copper	1	71	200100	Snapping Internal	4
19	160005	Plug Oil Drain-3/8" NPT	1	72	729000	Wristpin- LP Piston	1
20	701029	Cap Rear	1	73	720000	Piston LP	1
21	728000	Weight Unloader	2	74	719064	Piston Ring Set LP	1
22	100100	Pin - Hinge	2	75	727002	Valve Assy HP/LP Discharge	2
23	728002	Holder Unloader	1	76	727001	Valve Assembly-HP Inlet	1
24	723003	Spring Unloader	1	77	727004	Spacer Discharge Valve	2
25	728003	Plunge Unloader	1	78	727135	Retainer Discharge Valve	3
26	070166	Gasket Unloader Cover	1	79	070202	Copper Valve Seat Gasket	5
27	728004	Centrifugal Unloader Adapter Plate	1	80	727000	Valve Assembly-LP Inlet	2
28	110104	Capscrew Skt HD M6X20	4	81	727003	Spacer Inlet Valve	3
29	704000	Elbow Valve and Unloader	1	82	120055	Locknut	2
30	725243	Cooper Tube	1	83	727300	Retainer Inlet Valve	1
31	120058	Nut Adjustment Lock	1	84	070170	Gasket Valve Cover	3
32	703011	Breather	1	85	727136	Cover Valve	3
33	718006	Straight Breather Connector	1	86	725226	Finger Inlet LP	2
34	703017	Breather Tube	1	87	725224	O Ring Plunger 9 X 1.8	2
35	718015	Breather Elbow	1	88	725220	Plunger	2
36	712005	Filter Inlet Assembly	1	89	725204	Hold Down Cover Inlet LP	1
37	712006	Filter Element	1	90	718073	Tube Ell 1/4 x 1/4 Copper	1
38	070203	Gasket Copper	6	91	724035	Unloader Tube d6X280 HP	1
39	110107	Capscrew Hex M10 X 25	6	92	031797	Copper Nut Unloader Tube	3
40	070162	Gasket Cylinder To Crankcase	1	93	042384	T Fitting Copper 1/4 X 1/4 NPT	1
41	711000	Cylinder	1	94	724033	Hold Down Cover Discharge	1
42	706004	Aftercooler	1	95	031796	Copper Ring Unloader	1
43	718200	Tube Str. Connector 1/8(M)XM12	1	96	724031	Hold Down Inlet Cover	1
44	160003	Elbow Street 90 Degrees 1/4"	2	97	723100	Spring	2
45	722007	Valve Safety 200 PSI ASME	1	98	725228	Finger Inlet HP	1
46	070167	Gasket Aftercooler	2	99	705003	Dipper Oil	2
47	706002	Elbow Aftercooler	1				
48	110106	Capscrew SKT Head M8 X 25	4				
49	070161	Gasket Cylinder Head	1				
50	130058	Lockwasher 8	8				
51	110111	Capscrew Hex M12 X 70	8				

Installation Instruction

1. Inspection

Check for possible damage in transit and see that the pulley turns freely by hand Report any damage to delivering carrier at once.

2. Location

Select a clean, dry and light location. In cold climates the compressor should be installed in a heated building Insulate cold water or other low temperature pipes that pass overhead to avoid the possible collection and dripping of condensate onto the compressor and motor which could cause rusting and or motor shorting Do not install the compressor in a boiler room, paint spray room or area where sandblasting is carried on. If air in the area where the compressor is to be installed is acid-laden, or dust laden the compressor intake should be piped to the outside This intake pipe should be increased one pipe size for every twenty (20) feet of run and the intake filters should be installed at the end of the pipes with a hood to protect them from the elements.

If the compressor has to be located where the motor will be exposed to appreciable quantities of water, oil dirt, acid or alkaline fumes the motor must be of special construction to avoid rapid deterioration.

Bolt the unit securely and evenly to a level base. Unless base is exactly level, shims will probably be required. Any space between base and foot should be shimmed rather than drawing foot down thus placing strain on unit. When the unit is properly shimmed vibration will be nominal.

Allow sufficient space around compressor so that it is accessible from all sides for maintenance. Mount unit with pulley side toward the wall. but at least six (6) inches from it.

3. Starting

A. If compressors are shipped without oil in the crankcase. Before starting, fill crankcase to the high level mark on the sight glass with LaPlante compressor oil meeting the following specifications

AMBIENT OR ROOM TEMP. °F	VISCOSITY AT 100° F S.S.U.	FLASH POINT °F (Min.)	POUR POINT °F (Min.)	CARBON RESIDUE %o (Max.)	PREFERRED BASE
55 to 120	490 to 600	430	• 20	15	Naphthenic
32 to 55	290 to 350	390	* 5	10	Naphthenic
0 to 32	160 to 230	350	-10	.05	Naphthenic
Above 120 or below 0	CONSULT FACTORY				





For operation in damp or humid locations, addition of rust inhibitor is recommended.

B. Turn compressor over a few revolutions by hand to make sure that everything is free and in running condition.

C. Check tension of the belts (See Paragraph 6).

D. Remove tools, rags and any other objects from the vicinity of the compressor.

E. Never put hands on the belts of idle units, unless main power is secured.

F. Note direction of arrow on flywheel and be sure direction of rotation is correct when machine is started. Correct direction is counter-clockwise when standing facing the flywheel. Air should be drawn through inter-cooler onto the cylinders for maximum cooling



Head unloader

Cylinder Head and Inlet Valve Unloader Assembly Detail

Explode drawing

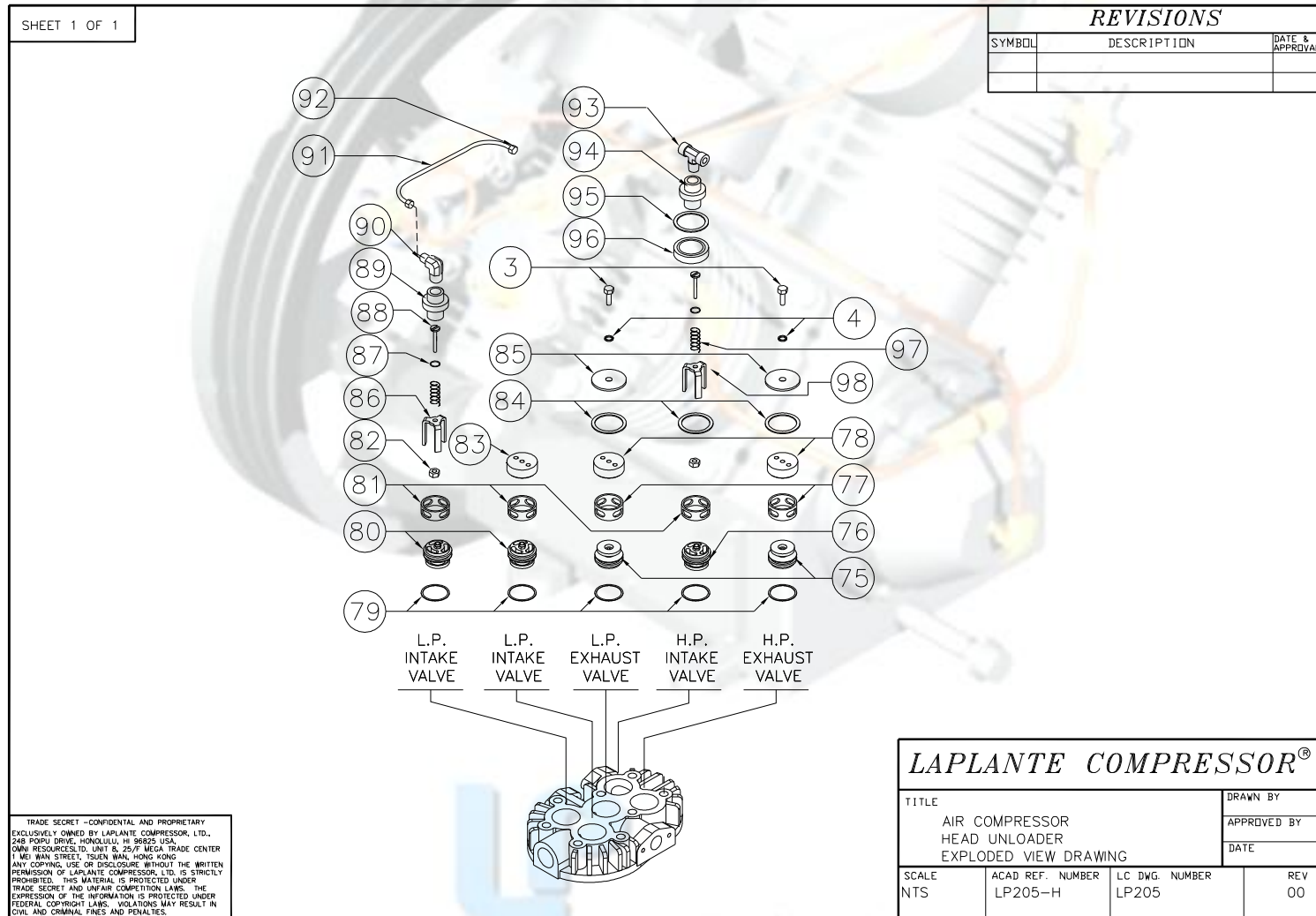

Bom list

LP205 Head Unloader Parts List			
Item	LAP#	Description	QTY
3	110117	Capscrew Hex M8X20	2
4	070201	Gasket Copper	2
75	727002	Valve Assy HP/LP Discharge	2
76	727001	Valve Assembly-HP Inlet	2
77	727004	Spacer Discharge Valve	2
78	727135	Retainer Discharge Valve	3
79	070202	Copper Valve Seat Gasket	5
80	727000	Valve Assembly-LP Inlet	2
81	727003	Spacer Inlet Valve	3
82	120055	Locknut	2
83	727300	Retainer Inlet Valve	1
84	070170	Gasket Valve Cover	3
85	727136	Cover Valve	3
86	725226	Finger Inlet LP	2
87	725224	O Ring Plunger 9 X 1.8	2
88	725220	Plunger	2
89	725204	Hold Down Cover Inlet LP	1
90	718073	Tube Ell 1/4 x 1/4 Copper	1
91	724035	Unloader Tube d6X280 HP	1
92	031797	Copper Nut Unloader Tube	3
93	042384	T Fitting Copper 1/4 X 1/4 NPT	1
94	724033	Hold Down Cover Discharge	1
95	031796	Copper Ring Unloader	1
96	724031	Hold Down Inlet Cover	1
97	723100	Spring	2
98	725228	Finger Inlet HP	1

Operation

The inlet valve unloaders are designed to provide **CONSTANT SPEED CONTROL** by holding open the inlet valves in both cylinders. When the air supply exceeds the demand and the discharge pressure rises above the maximum required, the pilot valve (not shown) admits air at discharge pressure to a plunger in each unloader, holding the inlet valve discs off their seats. Thus the air drawn into the cylinders is freely discharged without being compressed. When the pressure has dropped to the desired minimum, the pilot valve closes, allowing the inlet valves to seat and compression to be resumed.

Safety information



Please observe the following instructions when performing any maintenance, cleaning, repair work; when relocating the compressor plant; prior to installing and dismantling component parts, receivers, fittings and screw connections.

- **Always isolate the compressor at the main switch prior to performing any maintenance work. Secure the main switch against accidental switching on! Remove the electrical fuses in order to avoid accidents!**

- **Depressurize the compressor!**

Disconnect from the compressed air network by closing the ball valve on the compressed air outlet.

Perform maintenance or servicing work.

Only allow skilled and qualified welders to perform welding work on compressed air receivers!

After welding work on compressed air receivers, new constructional and hydrostatic pressure tests are to be carried out.

- **Prior to switching on again, check whether anyone else is working on the compressor!**

For your own safety, never omit a safety step!

Otherwise you will risk injury from restarting, electric shock or parts which may fly off!



Important!

Clean up the pump and package, before doing any install and maintenance work!!

Installation

Place seat gaskets (79), valves (76 & 80) and cages (81) into head in sequence as shown. Install "O" ring (87) on plunger (88) and assemble with spring (97) into inlet hold-down cover (89 & 94) . Assemble fingers (86 & 98) and locknut (82) to complete assembly.

Install hold-down cover assemblies with "O" rings (95). Connect unloader tube (91) to tube elbow (90) and tube tee (93). Connect tubing from pilot valve to tube tee (93).

Lubrication

When assembling plunger, (88) and "O" ring (87) to hold-down cover (89&94), coat "O" ring with silicon grease to facilitate assembly.

Service

Dirt in unloader line or defective pilot valve could hold valve open allowing unloading fingers to keep inlet valves open. Sometimes tapping the pilot valve will allow pilot valve to resume normal operation. If not, remove, clean or replace. Also broken "O" ring (87) may cause erratic operation. Refer to unloader pilot operation and maintenance details.



IMPORTANT: When ordering parts, give **MODEL** and **SERIAL NUMBERS** of compressor.



Centrifugal Unloader

Explode drawing

SHEET 1 OF 1

REVISIONS

SYMBOL	DESCRIPTION	DATE & APPROVAL

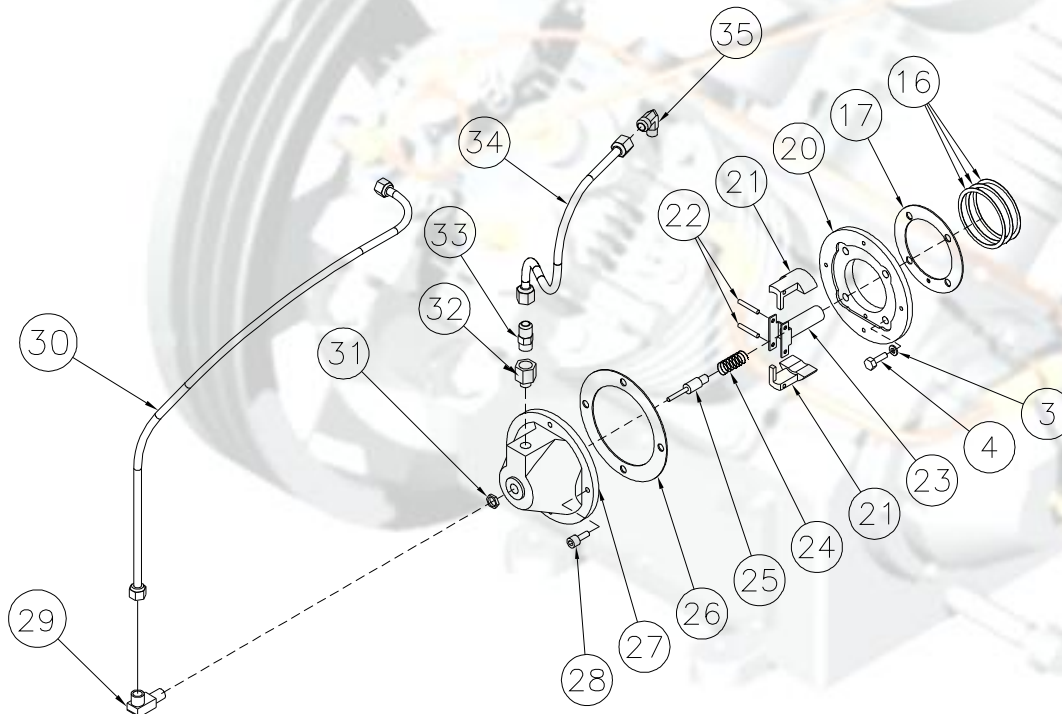

TRADE SECRET - CONFIDENTIAL AND PROPRIETARY
 EXCLUSIVELY OWNED BY LAPLANTE COMPRESSOR, LTD.,
 248 POPOI DRIVE, HONOLULU, HI 96825 USA,
 OMNI RESOURCES, LTD. UNIT 8, 25/F MEGA TRADE CENTER
 1 MEI WAN STREET, TSUEN WAN, HONG KONG
 ANY COPYING, USE OR DISCLOSURE WITHOUT THE WRITTEN
 PERMISSION OF LAPLANTE COMPRESSOR, LTD. IS STRICTLY
 PROHIBITED. THIS MATERIAL IS PROTECTED UNDER
 TRADE SECRET AND UNFAIR COMPETITION LAWS. THE
 EXPRESSION OF THE INFORMATION IS PROTECTED UNDER
 FEDERAL COPYRIGHT LAWS. VIOLATIONS MAY RESULT IN
 CIVIL AND CRIMINAL FINES AND PENALTIES.

LAPLANTE COMPRESSOR®

TITLE		DRAWN BY	
AIR COMPRESSOR CENTRIFUGAL UNLOADER EXPLODED VIEW DRAWING		APPROVED BY	
SCALE		DATE	
NTS	ACAD REF. NUMBER LP205	LC DWG. NUMBER LP205	REV 00

Bom list

LP205 Centrifugal Unloader Parts List			
Item	LAP#	Description	QTY
3	110117	Capscrew Hex M8X20	19
4	070201	Gasket Copper	24
15	090095	Shim .015 Brg Adjustment	1
15	090094	Shim .010 Brg Adjustment	1
16	090093	Shim .005 Brg Adjustment	1
17	070172	Gasket Rear Cap	1
20	701029	Cap Rear	1
21	728000	Weight Unloader	2
22	100100	Pin - Hinge	2
23	728002	Holder Unloader	1
24	723003	Spring Unloader	1
25	728003	Plunge Unloader	1
26	070166	Gasket Unloader Cover	1
27	728004	Centrifugal Unloader Adapter Plate	1
28	110104	Capscrew Skt HD M6X20	4
29	704000	Elbow Valve and Unloader	1
30	725243	Cooper Tube	1
31	120058	Nut Adjustment Lock	1
32	703011	Breather	1
33	718006	Straight Breather Connector	1
34	703017	Breather Tube	1
35	718015	Breather Elbow	1

Operation

The centrifugal unloader is designed to give "loadless" starting to the compressor units to which it is applied. When the current to the motor is interrupted or if the pump stops, for any reason, the centrifugal unloader will release the air in the aftercooler and head. When the unit resumes operation, the unloader valve closes allowing a build up of tank pressure. **WARNING** — When using 3 phase motors be sure of proper rotation or weight retainer assembly will work loose in a very short time. Test motor rotation without belts assembled. Correct rotation is counter-clockwise when facing flywheel side.

Safety information



Please observe the following instructions when performing any maintenance, cleaning, repair work; when relocating the compressor plant; prior to installing and dismantling component parts, receivers, fittings and screw connections.

- **Always isolate the compressor at the main switch prior to performing any maintenance work.**

Secure the main switch against accidental switching on! Remove the electrical fuses in order to avoid accidents!

- **Depressurize the compressor!**

Disconnect from the compressed air network by closing the ball valve on the compressed air outlet.

Perform maintenance or servicing work.

Only allow skilled and qualified welders to perform welding work on compressed air receivers!

After welding work on compressed air receivers, new constructional and hydrostatic pressure tests are to be carried out.

- **Prior to switching on again, check whether anyone else is working on the compressor!**

For your own safety, never omit a safety step!

Otherwise you will risk injury from restarting, electric shock or parts which may fly off!



Important!

Clean up the pump and package before doing any install and maintenance work !!

Installation

The centrifugal unloader weight retainer assembly (21, 22, 23, 24 & 25) may be assembled to crankshaft in either of two methods. Preferred method is by mounting to crankshaft when crankshaft is removed from base during assembly of pump.

The second method is used when only the centrifugal unloader is to be dismantled and only end cover (27) is removed, then centrifugal unloader weight retainer assembly (21, 22, 23, 24 & 25) may be assembled when crankshaft is in base. Assemble assembly into tapped hole in crankshaft (L. H. Threads). Apply wrench to weight retainer (21) to tighten snugly. Do not bend wings of weight retainer. Assemble end cover (27) end cover gaskets (16) to pump base with capscrews (28). Check end play of crankshaft in accordance to pump part sheet instruction. Insert plunger (25) into valve elbow assembly (29 & 30) and screw into end cover until part of valve (25) can be seen when looking into tube opening of elbow (20). Do not screw elbow into end cover too far or unloader will not operate properly. Secure valve elbow assembly in position by tightening jam nut (30).

Connect unloader tube (34) to elbow in high pressure discharge hold-down cover and valve elbow (35). Connect breather tube to elbow in head and to straight connector (32) in end cover.

Lubrication

When assembling unloader unit, lubricate plunger (26) and rivets (22) with good grade of machine oil.

Service

Leakage of air out through the unloader valve elbow opening after the unit has been shut off for a time, is an indication of a check valve leak and should be corrected by repair or replacement.



IMPORTANT: When ordering parts, give **MODEL** and **SERIAL NUMBER** of compressor.

Operation

Every compressor undergoes a trial run in the factory and is carefully tested and set. However, damage occurring afterwards, e.g. during transport, cannot be excluded. Therefore, the compressor should always be subjected to a trial run during commissioning and carefully monitored.



Before starting pump, the following must be done:

Check power supply;

Check oil level; top up if necessary;

Check fastener and piping connection.

For 3-phase power:

To insure there are no problems; start-up pump to check direction of rotation, counter-clockwise is correct.

If not, please change 2 of 3-phase power wiring.

If all items are ok, start the pump.



Parts Kits

parts kits include 7 sets:

1. Service Kit
2. Valve Kit;
3. Overhaul Kit;
4. Centrifugal Unloader Kit;
5. Head Unloader Kit;
6. Piston Set;
7. Piston Ring Set;



For each pump you can find the relevant parts kits number and describe in the explode drawings and bom list section.

The parts kits list as follow:

L010201		
Service Kit		
712005	Filter	1
712006	Filter Element	1

L010004		
Gasket Set		
L070163	Gasket Front Cap	1
L060068	Oil Seal	1
L070172	Gasket Rear Cap	1
L070162	Gasket Cylinder to Crankcase	1
L070161	Gasket Cylinder Head	1
L070164	Gasket Side Cover	1
L090093	Shim.005 Brg Adjustment	1
L090094	Shim.010 Brg Adjustment	1
L090095	Shim.015 Brg Adjustment	1
L070167	Gasket Aftercooler	2
L070169	Gasket Intercooler	2
L070170	Gasket Valve Cover	3
L070202	Copper Valve Seat Gasket	5
L070203	Gasket Copper	6
L070201	Gasket Copper	23

L010002		
Ring Set		
L719064	Piston Ring Set L.P.	1
L719088	Piston Ring Set H.P.	1

L010003		
Valve Set		
L727001	Valve Assembly-Inlet	1
L727000	Valve Assembly-LP Inlet	2
L727002	Valve Assy LP/HP Discharge	2
L070170	Gasket Valve Cover	3
L070202	Copper Valve Seat Gasket	5

L010098		
Overhaul Kits		
L010004	Gasket Set	1
L010002	Ring Set	1
L010003	Valve Set	1
L050122	Insert Rod-Bearing Half	4
L712006	Filter Element	1

010204		
Centrifugal Unloader Kit		
070166	Gasket Unloader Cover	1
100100	Pin - Hinge	2
723003	Spring Unloader	1
728000	Weight Unloader	2
728002	Holder Unloader	1
728003	Plunge Unloader	1

010205		
Head Unloader Kit		
031797	Copper Nut Unloader Tube	3
031796	Copper Ring Unloader	1
042384	T Fitting Copper 1/4 X 1/4 NPT	1
718073	Tube Ell 1/4 x 1/4 Copper	1
725204	Hold Down Cover Inlet LP	1
725220	Plunger	2
725224	O Ring Plunger 9 X 1.8	2
725226	Finger Inlet LP	2
725228	Finger Inlet HP	1
120055	Locknut	2
724031	Hold Down Inlet Cover	1

724033	Hold Down Cover Discharge	1
724035	Unloader Tube O.D.6X280 HP	1
723100	Spring	2

010206		
Piston Set		
050121	Needle Bearing	2
050122	Insert Rod-Bearing Half	4
100101	Dowel alignment	4
110102	Capscrew SKT Head M10x45	4
130060	Lockwasher M10	4
200100	Snapping Internal	4
705003	Dipper Oil	2
705107	Rod Connecting steel w/Needle Bearing	2
719064	Piston Ring Set; LP	1
719088	Piston Ring Set; HP	1
720000	Piston; LP	1
720002	Piston; HP	1
729000	Wristpin- LP Piston	1
729006	Wristpin HP Piston	1

Safety information



Please observe the following instructions when performing any maintenance, cleaning, repair work; when relocating the compressor plant; prior to installing and dismounting component parts, receivers, fittings and screw connections.

- Always isolate the compressor at the main switch prior to performing any maintenance work.

Secure the main switch against accidental switching on! Remove the electrical fuses in order to avoid accidents!

- Depressurize the compressor!

Disconnect from the compressed air network by closing the ball valve on the compressed air outlet.

Perform maintenance or servicing work.

Only allow skilled and qualified welders to perform welding work on compressed air receivers!

After welding work on compressed air receivers, new constructional and hydrostatic pressure tests are to be carried out.

- **Prior to switching on again, check whether anyone else is working on the compressor!**
For your own safety, never omit a safety step!
Otherwise you will risk injury from restarting, electric shock or parts which may fly off!

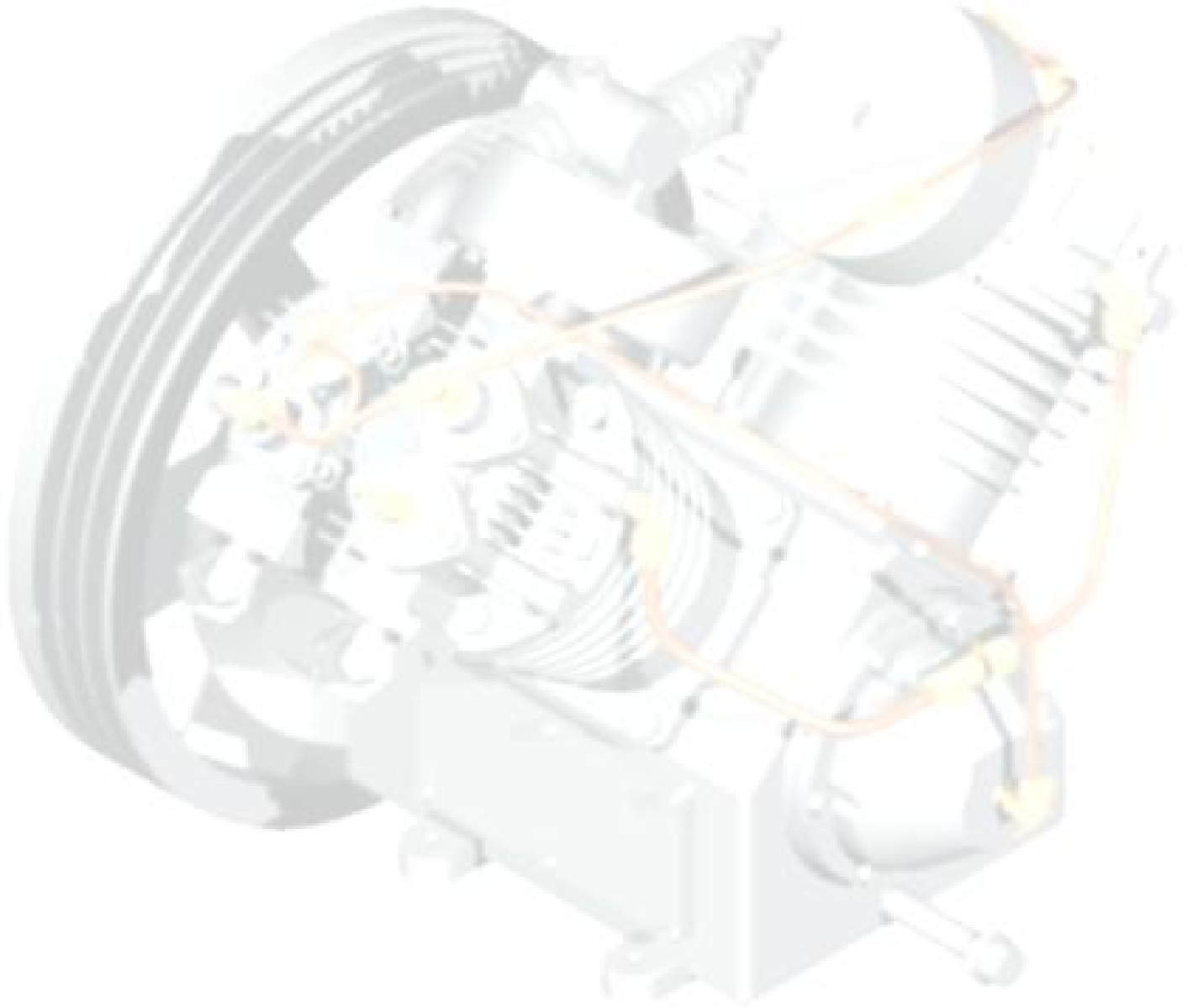

Bolt torque chart

Bolts Size	Grade	Torque(Ft.-Lb.)	Position
M6X20	8.8	5.5	End Cover Bolt
M6X25	8.8	5.5	End Cover Bolt
M6X35	8.8	5.5	Head to Cylinder Bolt
M8X20	8.8	13.5	LP & HP Hold Down Bolt
			End Cover Bolt
M8X25	8.8	13.5	Cylinder to Base Bolt
M8X35	10.9	13.5	Connecting Rod Bolt
M8X60	8.8	13.5	Head to Cylinder Bolt
M8X65	8.8	13.5	Head to Cylinder Bolt
M10X25	8.8	26	Cylinder to Base Bolt
M10X45	10.9	26	Connecting Rod Bolt
M12X35	8.8	45	Cylinder to Base Bolt
M12X70	8.8	45	Head to Cylinder Bolt
M12X110	8.8	45	Cylinder to Base Bolt
M16X80	8.8	110	Flywheel Bolt

Disassembling Pump

Before dismantling a pump for overhauling it is advisable to obtain a set of valve parts, piston rings, and gaskets in addition to other required parts.

- A. Loosen motor, slide toward pump and remove belts. Drain oil from crankcase and if desired, remove complete pump from plat form.
- B. Remove flywheel bolt and remove pulley using a wedge or wheel puller if required. Remove key File edges of key way smooth to remove sharp edges which could cut oil seal during removal.
- C. Remove intercooler and aftercooler from cylinder head. Remove air inlet filter from head.
- D. Remove cylinder head from cylinder by removing cap screws.
- E. Before removing cylinder mark top of pistons nearest flywheel, so that they can be reinstalled in same position. Remove cylinder by removing bolts Cylinder can be removed easily by twisting slightly back and forth while pulling upward. Care should be taken that connecting rod and piston does not become damaged from striking metal when cylinder is removed The condition of cylinder, pistons, rings and bearing fits can then be checked.
- F. Remove end cover and slide crank shaft with connecting rods, pistons, etc. out of base being careful not to damage the oil feeder ring. Place pulley end of crankshaft in a vice

- using a soft jaws to prevent damage.
- G. To remove pistons. Remove roll pins, by driving them into the wrist pins, and push out wrist pins. Remove roll pins from wrist pins.
 - H. When removing connecting rods see that rods and caps are kept in matched sets, noting the position with reference to the crankshaft of the identification marks on one side of each so that the connecting rod can be replaced in the same position it originally occupied.
 - I. Drive oil seal out of base (only if replacement is necessary) with evenly spaced blows from inside.
 - J. To dismantle head, remove low pressure hold-down covers and high pressure hold-down covers by removing cap screws. Lift out low pressure cages and high pressure cages. Low pressure valves and high pressure valves can be lifted out as well as the low pressure seat gasket (15. fig. 4) and high pressure seat gasket.
 - K. To dismantle valves, place valve in a soft jaw vise and remove center screw Valves are now free to take apart Clean all parts thoroughly. Valve plates and seats- (must be smooth and flat and can sometimes be resurfaced by rubbing on fine emery cloth held on a smooth surface. Badly worn parts including springs, which lose tension after considerable use should be replaced.

Fitting and Reassembling



Clean all parts thoroughly before assembling.

- A. Crankshaft — Base
Be sure base is cleaned to remove all metal chips and dirt. Insert crankshaft and oil feeder ring only into base assemble end cover and tighten end cover bolts evenly. End cover gaskets or shims are furnished in three thicknesses and the proper combination must be selected so that crankshaft can be "spun" in the bearings without "end play". Also see that oil feeder ring turns freely within the guide lugs in the base. Then remove crankshaft.
- B. Piston — Cylinder
Check fit before assembling pistons to connecting rods. Pistons without rings should slide through the cylinder of their own weight and holding the skirt of the piston with the two thumbs there should be no appreciable side motion at any point of piston travel. Scored cylinders or pistons should be replaced. C. Wrist Pins should be "tap" fit by hammer. See that roll pin holes are in line.
- D. Wrist Pin — Needle Bearing
Fit so that piston can be "rocked" with three fingers — the thumb on one side and index and middle fingers on the other. The piston should not rock of its own weight. Drive roll pin into wrist pin when piston and wrist pin holes are in line and piston is assembled to connecting rod. If replacement of a needle bearing ever becomes necessary, be sure to press in the new bearing so that the small hole through casting lines up with oil hole in rod. Wrist pin should also be replaced.
- E. Connecting Rod — Crankshaft Tap cap, when insert bearings are assembled to rod and cap

- to make sure bearing is making contact and tighten rod bolts with lock washers in place to prevent loosening (torque — 25 foot pounds). The combined piston and connecting rod should turn slowly on the crankshaft of their own weight if bearing adjustment incorrect. It will be noted that ends of the inserts extend slightly above the parting line of the rod and cap and under no circumstance should these ends of the inserts be filed.
- F. Reinstall crankshaft with pistons and connecting rods attached being careful not to damage oil feeder ring when fitting within base lugs and being sure there are no burrs or dirt on the pulley end of the crankshaft that might cut the oil seal.
 - G. If oil seal is to be replaced slide over the crankshaft and press into place in the base, the lip or seal side toward the crankcase. Do not hammer directly on the seal.
 - H. Replace valve parts in sequence indicated in explode drawing being careful not to force any parts together when tightening this center screw and locknut (Torque — 28 foot — pounds). After assembly .depress valve plate to insure that the valve works freely.
 - I. Head Assembly
Install seat gaskets valve assemblies Cages, "O" rings, Hold down covers and cap-screws. Tighten cap screws evenly so as not to break corners of hold down covers (Torque — 10 foot — pounds), Assemble head to cylinder (Torque -10 foot - pounds).
 - J. Install key and pulley after cylinder head, intercooler and after-cooler are connected.
 - K. Turn pulley over by hand several times to insure that no interference of any kind exists.
 - L. "Running in" for a few hours without the head assembly is recommended if a pump has been completely overhauled — especially if new pistons and/or cylinders have been installed.

Valves

Valves are generally considered to be maintenance items and require care by the user. They are the most important part of the compressor and the importance of proper care and maintenance cannot be over-emphasized.

All valves should be removed from the cylinder head at the end of the first two or three months of operation and examined for cleanliness and carbon formation. Clean with safety solvent and blow off with compressed air. Depending on what is found at this inspection, the next inspection should not be more than 4 to 6 months later. These 2 inspections will guide you in scheduling periodic cleaning times which will pay off many times over in providing trouble free service and reduced down time.

Troubleshooting

1. Slow Pumping Or Insufficient Pressure Can Be Caused By

- A Clogged inlet filter — (Disassemble and clean thoroughly.)
- B Leaks in air lines, valves, fittings, etc. (Locate using soapy water if necessary: replace or tighten threaded parts.)
- C Compressor too small for equipment being operated — (Check air requirements and add to compressor capacity — consult dealer.)
- D Leaking head valves - (Remove hold-down covers and remove valves for examination. Repair

or replace faulty valves.) Valves can be removed from head by tapping valve screw with hammer handle or piece of wood, to loosen valve from head, before lifting valve.

Clean all parts thoroughly. Valves and seats must be flat and smooth and sometimes can be resurfaced by rubbing on fine emery cloth held on a smooth flat surface. Badly worn parts, including springs which lose tension after considerable use should be replaced. Reassemble valve parts in sequence indicated in explode drawing. Examine valve gaskets carefully and replace if doubtful of condition. Be careful that nothing falls into the cylinder that could get caught between top of piston and cylinder head. Before reassembling valve look into cylinder through valve opening while turning flywheel by hand.

2. Excessive Oil Consumption

"Oil Pumping" usually results from using the wrong type or an inferior grade of oil. Replacing worn or stuck piston rings will help correct this condition but contrary to popular belief, worn rings do not affect pumping efficiency appreciably.

Piston rings can be replaced by removing cylinder while the heads are off. Remove rings and clean grooves in piston.

The low pressure oil ring provided is of the latest design and is the same as furnished on the new automobile engines. It is of three-piece construction with two chrome-plated rails and an expander ring. Some new units may pump a slight amount of oil for a period of time but as the chrome-plated rails seat to the cylinder walls this will gradually diminish. Should excessive oil consumption continue, the cylinders should be checked for scoring and the oil ring checked for proper assembly. The two ends of the expander rings are colored with paint for identification and when properly assembled should be butted, not overlapped. The high pressure oil ring is of the one piece construction.

A coating of clean oil should be placed on the rings and the inside of the cylinders for ease of assembly and to minimize possibility of scoring cylinder. See Paragraph 16 for reassembly procedure.

3. Noisy Operation Can Be Caused By

- A. Loose parts — external — (Tighten loose bolts, particularly the flywheel pulley to the crankshaft.)
- B. Foreign matter such as carbon, metal chips, etc. on pistons striking head at top of stroke (Remove head and clean).
- C. Piston extending above cylinder at top of stroke and hitting head. (Remove cylinder and add base gasket, not upper cylinder gasket.)
- D. End play in crankshaft — (Remove end cover, take out one end cover gasket or shim and replace). Do not remove too many shims or binding may result, see Paragraph under fitting and reassembling.
- E. Loose valves — Hex head cap screws are not tight enough. (Tighten screws)



Screws should be tightened snugly but not too tight as hold-down cover corners could be broken.

Screws should be tightened evenly keeping covers parallel with cylinder head. Screws have nylon insert in threads and are of self-locking construction. They will not loosen from vibration and can be removed and retightened several times without losing their holding ability.

F. Loose or worn parts — Internal, e.g. pistons, connecting rods, wrist pins, valves — (Pump should be overhauled — preferably in distributors service department or factory. Loose rod bolts can be tightened after removing crankshaft, but if bearings are worn or scored, new insert bearings must be installed.)

4. Oil Leak

At base or end cover gasket — (Disassemble at point of leak, shellac or perma-gasket on both sides and reassemble. Maintain correct oil level).

5. Vibration

Characteristic of all reciprocating machines can be held to a minimum by keeping the compressor securely fastened to a solid level foundation, maintaining proper belt alignment and keeping nuts and bolts tight.

6. Overheating

Compression of air generates heat, much of which is dissipated as air passes over the intercooler and/or aftercooler. Overheating can be caused by:

- A. Pump running backwards — (Reverse direction.) Proper rotation is counterclockwise facing flywheel.
- B. One or more head valves failing to seat properly — (Remove hold-down cover, valve cage, and valve. Clean, reseal or replace valves.)
- C. Blown cylinder head gasket — (Replace after cleaning all traces of old gasket from head and cylinder.)
- D. Restriction in head, intercooler or check valve if used. — (Remove and clean.)
- E. Lack of oil — (Check oil level, if necessary, remove side plate to see that oil feeder ring is free to turn.)
- F. Dirt in intercooler fins or cylinder fins - (Blow out with air.)
- G. Poor ventilation and high room temperature
(If compressor cannot be moved, check possibility of piping intake to cooler location.)

7. Compressor Has No Or Insufficient Output

- A. Suction filter soiled-(Clean suction filter)
- B. Suction and pressure valves worn or defective-(Replace valves)
- C. Vent (unloading) valve does not close-(Check whether the vent (unloading) valve closes when the compressor is running; overhaul or replace valve, if necessary)

8. Safety Valve Of The First Stage Blows Off

- A. Suction and pressure valves of the second stage defective or worn-(Replace valves)
- B. Seal between valve and cylinder head defective-(Replace seal)

9. Oil Foam in The Crankcase

- A. Last stage piston worn-(Operate compressor with final stage valve head removed. If oil

collects at rim of cylinder, piston clearance ok. If oil flows continuously out of cylinder, replace piston and liner)

B. Last stage outlet valve defective-(Replace)

10. Oil out of from the breather

Compressor piston jammed-(Replace pistons and cylinders)

Maintenance



To obtain reliable and satisfactory service, this unit requires a consistent preventive maintenance program. Maintenance schedule pages are included in the back of this manual to aid in keeping the proper records.

General

1. Check your compressor regularly!
2. Check entire system for air leakage around fittings, connections, and gaskets, using soap solution.
3. Remove dust or oil soiling.
4. Check fastener tightness by using torque wrench to the corresponding values within this guide.

Safety information



Please observe the following instructions when performing any maintenance, cleaning, repair work; when relocating the compressor plant; prior to installing and dismounting component parts, receivers, fittings and screw connections.

- Always isolate the compressor at the main switch prior to performing any maintenance work.

Secure the main switch against accidental switching on! Remove the electrical fuses in order to avoid accidents!

- Depressurize the compressor!

Disconnect from the compressed air network by closing the ball valve on the compressed air outlet.

Perform maintenance or servicing work.

Only allow skilled and qualified welders to perform welding work on compressed air receivers!

After welding work on compressed air receivers, new constructional and hydrostatic pressure tests are to be carried out.

- Prior to switching on again, check whether anyone else is working on the compressor!
For your own safety, never omit a safety step!
Otherwise you will risk injury from restarting, electric shock or parts which may fly off!

Check oil level

Check oil level every week and top up, if necessary: fill the oil tank with oil until the sight glass is 1/4 to 3/4 full.

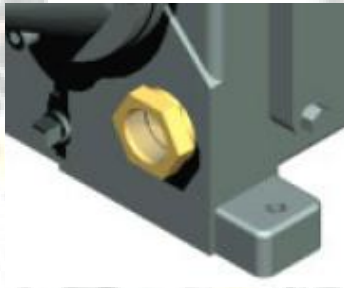

Oil sight glass



Use the same brand oil

Check and clean compressor valves

if compressor fails to pump air or seems slow in filling up tank, disconnect unit from power source and remove valves and clean thoroughly, using compressed air and a soft wire brush. After cleaning exceptional care must be taken that all parts are replaced in exactly the same position and all joints must be tight or the compressor will not function properly. When all valves are replaced and connections tight, close hand valve at tank outlet for final test. Valve gaskets should be replaced each time valves are removed from pump. Replace springs, discs and seats when worn or damaged.



Valves must be reinstalled in original position. Incorrect valve replacement may result in overpressure of the cylinder head resulting in catastrophic failure, injury or death. Valve gaskets should be replaced each time valve are serviced.

Checking the safety valve



The safety valve must respond when the compressor pressure increases too high.

The inter stage pressure relief valve is provided to protect against inter stage over pressure and is factory set for maximum pressure of 75 PSIG. If the pressure relief valve pops open, it indicates trouble. Shut down the unit immediately and determine and correct the malfunction. Inspect the head valves. Serious damage can result if not corrected and can lead to complete destruction of the unit. Tampering with the inter stage pressure relief valve, or plugging the opening destroys the protection provided and voids all warranty.

The valve must be able to blow off the entire delivery quantity of the compressor. As it is rarely or never operated, it is of utmost importance for the safety of the compressor that the valve is regularly checked. Check the valve once a year or after 2000 operating hours.

This is the only maintenance work which has to be performed while the compressor is running. Make sure that all safety devices are correctly installed! Never perform this work with the safety device removed! Danger of injury or death!



Do not readjust!!

Test safety valve on compressor:

A ring is located at the free end of the safety valve. Pull the ring by hand. Never remove the lead seal at the head of the valve!

If you now pull the ring further, the safety valve should blow off increasingly more air.

If the valve blows off correctly, dropt hand tight in its seating and complete the check.

- If the valve does not blow off although you have pull the ring up to the end of the stud, it is defective. Please have a new safety valve fitted by **LAPLANTE** Service.

Test the valve as described in section "Testing safety valve on compressor".

Compressor Oil

General

Compressors are factory filled with **LAPLANTE** hydrocarbon based recip lubricant. This is an ISO non-detergent industrial lubricant with rust and oxidation inhibitors specially formulated for reciprocating compressors. It is recommended this compressor be maintained using this oil for ambient temperature above 32 F degeed.

LAPLANTE synthetic is a premium grade diester based synthetic lubricant providing excellent performance in high temperature applications.



Do not mix oil types, weights or brands.



Normal break-in period of **LAPLANTE** air compressors is 25 hours.

for the first 500 hours of compressor operation, a careful and regular check of the oil level should be made. Maintain oil level at the full time.

Change To Synthetic Lubricant

If changing to synthetic lubricant, the following steps must be completed.

Compressor must run for a 25 hour break-in period using LAPLANTE ISO 100 oil.

Thoroughly drain existing oil from crankcase.

Fill crankcase with a full charge of synthetic lubricant.

Run compressor for 200 hours.

Stop compressor and thoroughly drain the synthetic lubricant.

Add a full charge of synthetic lubricant.

Compressor now ready to run for extended period before next lubricant change made. Maintain oil level at the full line.

Lubricant

Frequency Of Oil Change

Change oil every 3000 operating hours whichever comes first. For constant run applications in daily use or units subjected to extremely heavy use change oil monthly.

Oil Recommendation



Any Approved Oil Which Is Equal To Those Specified May Be Used

Ambient Or Room Temperature 55° F To 120° F

AMOCO	SHELL	MOBIL	TEXACO	CHEVRON	GULF	EXXON
#51	Tellus Oil 41 Rotella Oil 30	Del vac 1230 DTE Heavy	Regal ER&O	EP68X	Paramount 58	Teresstic 100

Ambient Or Room Temperature 32° F TO 55° F

AMOCO	SHELL	MOBIL	TEXACO	CHEVRON	GULF	EXXON
#31	Tellus Oil 33 Rotella Oil 20-20W	Delvac 1220 DTE Heavy Med.	Regal CR & O	EP55X	Paramount 49	Teresstic 68

Ambient Or Room Temperature 0° F TO 32° F

AMOCO	SHELL	MOBIL	TEXACO	CHEVRON	GULF	EXXON
#21	Tellus Oil 25 Rotella Oil 10W	Delvac 1210 DTE Medium	Cetus Oil	EP45X	Paramount 65	Teresstic 32

Suction Filter

Regularly and carefully maintain the suction filter approx. every 500 operating hours, depending on the degree of soiling of the air taken in. Soiled suction filters can cause high oil consumption and reduced delivery quantity! If the installation site is heavily contaminated with dust, provide a dry air filter with paper cartridge. If the ambient air is heavily contaminated, we recommend using dry air filters.

All compressors are available with a common air filter with under pressure display for all cylinders.

Clean air filter

Nearly 1500 operating hours or 1 year

Check air filter and clean, if necessary

After undoing the snap fasteners, lift the cover off and take out the filter cartridge. If the filter is soiled, clean as follows:

Clean the cartridge on the outside by an inclined air blast at max. 3-5 bar.

The cartridges can be cleaned up to three times before being replaced with new ones.

Nearly 1500 operating hours or 1 year to change the filter element

Clean the filter casing.

Carefully inspect the cartridge for damage. Only use completely intact filters cartridges!

Examine cover seal and replace with a new one if damaged.

Insert filter cartridge, replace casing cover and close with fastening clamps.



Cleaning the air filter

Maintenance intervals

We recommend servicing and maintaining your compressor at the following intervals. The hours of operation refer to average working conditions. Other intervals may apply depending on these conditions. Please contact LAPLANTE in this event.



Please record each maintenance task in the table on the last pages of these instructions! This may help **LAPLANTE-Service** to locate faults if any occur.

Maintenance work	Maintenance intervals dependent on usage		
	either after	or	
	Operating hours	weekly / monthly	yearly
Check oil level and top up, if necessary		weekly	
Check suction filter and clean, if necessary	500	monthly	
Replace suction filter cartridge	2000		X
Check safety valve	2000		X
Check cooler for soiling and clean, if necessary	500	monthly	
Change oil *	1.000		every 1 years
Check V-belt for damage and replace, if necessary	2.000		X

Motor

Carefully read and fully understand the Owner's Manual Prior to installation, operation and maintenance of your motor.

1. RECEIVING AND INSPECTION

Check packing list and inspect the motor to make sure no damage has occurred during shipment. Turn the motor shaft by hand to be certain that it rotates freely without any mechanical rubbing or other audible noise. Check the nameplate for conformance with power supply and control equipment requirements.

2. STORAGE



FALLING EQUIPMENT can injure or death

Lift only using equipment of adequate lifting capacity.

If so equipped, use lift ring(s) on the motor to lift ONLY the motor and mounted accessories

Motor stock areas should be clean, dry, vibration free and have a relatively constant ambient temperature. For added bearing protection while the motor is in storage, turn the motor shaft every 2~3 months.

Windings should storage, the resistance reading must not have dropped more than 50% from the initial reading. All external motor parts subject to corrosion, such as shaft and other machined surfaces, must be protected by applying a corrosion-resistant coating.

3. INSTALLATION

For maximum motor life, place the motor in a clean, dry, well-ventilated location easily accessible for inspecting, cleaning and lubricating.

3.1 INSTALLATION- MECHANICAL



MOVING PARTS can injure.

Before starting the motor, be sure the shaft key is captive.

Consider the application and provide guarding to protect personnel.

Base

Mount the motor on a firm foundation or base sufficiently rigid to prevent excessive vibration. If necessary, properly shim the motor to prevent undue stress on the motor frame and for better alignment of the unit.

Drive

The pulley, sprocket, or gear used in the drive should be located on the shaft as close to the shaft shoulder as possible. Belt Drive: Align the pulleys so that the belt(s) will run through.

Properly tension the belt; excessive tension will cause premature bearing failure.

Chain Drive: Align the sprockets so that the chain will run through. Avoid excessive chain tension. Gear Drive and Direct Connection: Accurate alignment is essential. Secure the motor and driven unit rigidly to the base. Shims may be needed to achieve proper alignment.

3.2 INSTALLATION-ELECTRICAL



ELECTRIC SHOCK can kill.

Disconnect input power supply before installing or servicing motor. Motor lead connections can short and cause damage or injury if not well secured and insulated. Use washers, lock washers and the largest bolt size which will pass through the motor lead terminals in making connections. Insulate the connection, equal to or better than the insulation on the supply conductors. Properly ground the motor-See Grounding. Check power supply to make certain that voltage, frequency and current carrying capacity are in accordance with the motor nameplate. Proper branch circuit supply to a motor should include a disconnect switch, short circuit current fuse or breaker protection, motor starter (controller) and correctly sized thermal elements or overload relay protection. Each of these should be properly sized and installed per the National Electrical Code and local codes.

Terminal Box

Remove the appropriate knockout. For terminal boxes without a knockout, either a threaded power-conduit entry hole is provided or the installer is responsible for supplying a correctly sized hole.

Motor Connection

See the nameplate.

GROUNDING



ELECTRIC SHOCK can kill.

Connect the motor frame to a good earth ground per the National Electrical code and local codes.



Motors may be electrically connected to earth ground using a terminal box mounting screw or a separate grounding screw when provided. In making the ground connection, the installer should make certain that there is a good electrical connection between the grounding lead and the motor

4. OPERATION

Power supply ratings conform to the requirements on nameplate, after checking that the shaft key is secure, operate the motor free of load and check the direction of rotation. If the motor rotates in the wrong direction, interchange any two supply leads.

Couple the motor to its load and operate it for a minimum of one hour. During this period, check for any unusual noise or thermal conditions check the actual operating current to be sure that the nameplate current times service factor is not exceeded for steady continuous loads.

5. MAINTENANCE



ELECTRIC SHOCK can kill.

Internal parts of the motor may be at line potential even when it is not rotating.

Disconnect all input power to the drive and motor before performing any maintenance.

Do not touch by hand the frame of working motor to prevent from being scalded.

Periodically inspect the motor for excessive dirt, friction or vibration. Dust may be blown from an inaccessible location using compressed air. Keep the ventilation openings clear to allow free passage of air.

BEARING SYSTEM

Motors have a high quality, premium design bearing system. Bearing sizes and enclosures are identified on most motor nameplates. The majority are double-shielded, deep-groove ball bearings. Double-sealed ball bearings are also used.

Check valve

General

The check valve closes when the compressor stops operating, preventing air from flowing out of the tank through the pressure release valve. After the compressor stop operating, if air continues to escape through the release valve, it is an indication that the check valve is leaking. This can be corrected by removing check valve and cleaning disc and seat. If check valve is worn badly, replace same.

Safety information



Before removing check valve be sure all air is drained out of tank and power is disconnected. Failure to do so may result in injury or equipment damage.

Air Receiver

General

Install the compressed air receiver such that nobody is endangered. Protect it from mechanical influences in as much that damage entailing dangerous consequences for persons is not be expected. Ensure that it is possible to operate the compressed air receiver and its equipment from a safe workplace.



Maintain the protection areas and protection space!

Safety information

Ensure that the compressed air receiver is securely mounted and cannot be displaced and tilted by external forces. This also includes the additional weight of the test medium during pressure testing! Where possible, ensure that the receiver is accessible from all sides for repetitive tests. Ensure that the company plate is easily visible.

It is forbidden to undertake repair and modification work which may influence the safety of the compressed air receiver. This applies in particular to work which may change the material properties. Do not undertake welding work on a receiver once the water pressure tests have been passed! Reinforcing plates for mounting plates and brackets are not considered as pressure bearing elements.



Suitable protect compressed air receiver against corrosion.

Adhere to the generally accepted rules of technology when maintaining and installing the receiver.

Checking the safety valve



The safety valve must respond when the compressor pressure increases too high.

The inter stage pressure relief valve is provided to protect against inter stage over pressure and is factory set for maximum pressure of 175 PSIG. If the pressure relief valve pops open, it indicates trouble. Shut down the unit immediately and determine and correct the malfunction. Inspect the head valves. Serious damage can result if not corrected and can lead to complete destruction of the unit. Tampering with the inter stage pressure relief valve, or plugging the opening destroys the protection provided and voids all warranty.

The valve must be able to blow off the entire delivery quantity of the compressor. As it is rarely or never operated, it is of utmost importance for the safety of the compressor that the valve is regularly checked. Check the valve once a year or after 2000 operating hours.

This is the only maintenance work which has to be performed while the compressor is running. Make sure that all safety devices are correctly installed! Never perform this work with the safety device removed!



Danger of injury or death!



Do not readjust!!

Test safety valve on tank:

A ring is located at the free end of the safety valve. Pull the ring by hand. Never remove the lead seal at the head of the valve!

If you now pull the ring further, the safety valve should blow off increasingly more air.

If the valve blows off correctly, drop hand tight in its seating and complete the check.

- If the valve does not blow off although you have pull the ring up to the end of the stud, it is defective. Please have a new safety valve fitted by **LAPLANTE** Service.

Condensate

Manually draining off condensate from the compressed air receiver

If no automatic condensate separator is fitted, drain off the condensate by hand at least once a week.



Depressurize the receiver.

Place a suitable collecting basin underneath the ball valve under the receiver.

Open the ball valve and allow the condensate to drain off into the collecting basin.

Once the condensate has completely drained off, close the ball valve again and correctly dispose of the condensate.

Safety information



Please observe the following instructions when performing any maintenance, cleaning, repair work; when relocating the compressor plant; prior to installing and dismantling component parts, receivers, fittings and screw connections.

- **Always isolate the compressor at the main switch prior to performing any maintenance work.**
Secure the main switch against accidental switching on! Remove the electrical fuses in order to avoid accidents!
- **Depressurize the compressor!**
Disconnect from the compressed air network by closing the ball valve on the compressed air outlet.
- **Perform maintenance or servicing work.**
- **Only allow skilled and qualified welders to perform welding work on compressed air receivers!**
After welding work on compressed air receivers, new constructional and hydrostatic pressure tests are to be carried out.
- **Prior to switching on again, check whether anyone else is working on the compressor!**

For your own safety, never omit a safety step!

Otherwise you will risk injury from restarting, electric shock or parts which may fly off!

Check V-belts for damage and replace with new ones, if necessary

The belts should be checked for damage and wear after every 2000 hours or once yearly.

- Remove the belt guard
- Turn the belts slowly using the fan wheel.
- Check - in addition to foreign bodies- for large eruptions in the flanks of the belts and for tears in the fabric indicating the belt is becoming brittle.

If it is necessary to change the belts, proceed as follows:

- Unscrew the four retaining screws with a suitable spanner from the slots in the motor plate.
- Completely slacken the V-belts. Turn the tensioning block using the spanner.
- Remove the belts from the pulleys and clean, if necessary.
- Check the flanks of the pulleys and clean, if necessary.
- Fit new V-belts. Only change the belts as a complete set, never individually!
- Retension the V-belts: Turn the tensioning spindle clockwise until achieving the correct belt tension, i.e. when a testing force of 30 N applied vertically to the belt between drive and flywheel causes the belts to sag by approx. 10 - 12 mm.
- After setting the correct belt tension, screw the motor plate firmly in place and replace the belt guard.

Magnetic Starter

Safety information



Please observe the following instructions when performing any maintenance, cleaning, repair work; when relocating the compressor plant; prior to installing and dismantling component parts, receivers, fittings and screw connections.

- **Always isolate the compressor at the main switch prior to performing any maintenance work. Secure the main switch against accidental switching on! Remove the electrical fuses in order to avoid accidents!**
- **Depressurize the compressor!**
Disconnect from the compressed air network by closing the ball valve on the compressed air outlet.
- **Perform maintenance or servicing work.**
- **Only allow skilled and qualified welders to perform welding work on compressed air receivers!**
After welding work on compressed air receivers, new constructional and hydrostatic pressure tests are to be carried out.
- **Prior to switching on again, check whether anyone else is working on the compressor!**

For your own safety, never omit a safety step!

Otherwise you will risk injury from restarting, electric shock or parts which may fly off!



General

- 1.1 Turn off power before carrying out any maintenance.
- 1.2 Please handle carefully and avoid abnormal vibration and shock.
- 1.3 Operational Temperature: -5°C ~ 55°C .
Storage Temperature I -40°C ~ 70°C ; Relative Humidity: 45-65%.
2. Installation and wiring:
 - 2.1 Ensure that specification (rated voltage and power, voltage and frequency of operation)
 - 2.2 Select appropriate conductor and tighten with appropriate torque with right tool. Connect with diagram connection inside box cover, if not fit .contact us.

2.3 Tightening torques for elements are given below:

Type		CU-11/16	CU-18/23	CU-27/32/3 8 CU-40	CU-50/65/80	RHN-10	RHN-80
Main Terminal	screw./blot	M3.5	M4	M5	M6	M4	M5
Aux. contact & Coil terminal	Kgf .cm tightening torque	6.5-10	10-15	20-30	35-50	10-15	20-30
	screw./blot	M3.5	M3.5	M3.5	M3.5	M3.5	M3.5
	Tightening torque	6.5-10	6.5-10	6.5-10	6.5-10	6.5-10	6.5-10

Tightening torque shall be within the values given above to avoid deteriorating the screws.

2.4 Mounting position shall be within the ranges specified below :

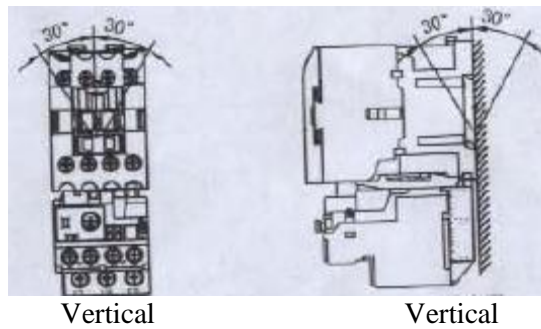

2.5 Ensure that the starter can be operated normally.

3. Countermeasures for normal malfunctions:

Malfunction	Causation	The contactor can not launch	The contactor launches but can not retain	The contactor can not operate	The contactor make noise	The coil burns out	The contactor tip fuses	Short circuit	The thermal overload relay trips	The thermal overload relay fuses	The thermal overload relay can not trips	The heater set of the thermal overload relay fuses	The motor burns out	The temperature of the tip raise	Countermeasures				
																The fuse breaks	Molded Case Circuit breaker trips	Voltage falls	Voltage is high
power	The fuse breaks	•										•			Research and change the fuse				
	Molded Case Circuit breaker trips	•										•			Research and reset				
	Voltage falls	•	•		•	•	•		•				•		Check-up the power				
	Voltage is high					•							•		Check-up the power				
contactor	contactor tip is dirty		•												Clean the contactor tip with the bumf				
	Coil breaks	•													Chang a new one				
	Layer short of Coil	•		•	•										Chang a new one				
	SH coil breaks			•											Change the contactor				
	The lipin on the contact tip					•	•							•	Clean but can't use menstruum				
	Contact tip fues			•											Chang all contact tips				
	Arc horn breaks way or unlocked						•	•							Change a new production or lock the arc chamber room				
Mechanism of the	Rectifier burns out	•													Chang a new one				
	The mechanism is dirty								•						Unpick and wash, select dustproof type				
	The core is dirty				•	•									Unpick and wash without lipin				
	Abrasion of core			•											Chang a new one				
	Phenolic part breaks	•		•											Chang a new one				
Thermal over relay load	The current set wrong								•	•			•		Set by the current designation of motor				
	The heater set fuses									•		•	•		Research and change a new one				
	The thermal overload relay trip	•													Research and reset				
	The thermal overload relay trip time is wrong								•	•			•		Change a new one				

Instruction Manual for Air Compressor Pressure Control

Model L7161181

General

Pressure switches

Pressure switches are mainly used to switch pump and compressor motors on and off depending on the pressure so that the pressure of a given media within a tank does not exceed an upper or fall below a lower value. The upper pressure value by which e.g. a pressure switch breaks an electric circuit (NC function) is called the cut-out pressure. The lower pressure value by which the pressure switch makes an electric circuit is called the cut-in pressure. Both cut-out and cut-in pressures within a given range can be set on the pressure switch. The reversed switching function by which the upper setting point makes an electric circuit and the of a lower setting point breaks the electric circuit is called NO function. The pressure switch related difference between cut-in and cut-out pressures is called hysteresis. Every pressure switch allows the natural hysteresis to be increased by a differential adjustment. An easy two-point control with a pressure switch is thus feasible.

Control pressure switches

Control pressure switches represent a special group within pressure switches. These devices are especially suitable for monitoring and controlling purposes.

Unloader valves- (EV) and delayed unloader valves (AEV)

Within the range of compressor technology, unloader valves are very often used. Unloader valves allow air within the feed line of the pressure tank to be bled off enabling pressure less start of the motor when the pressure switch switches off the motor, extending the life cycle of the motor. The delayed unloader valve has the same function and additionally supports the motor when starting in that it remains open until a certain pressure (approx. 2 bars) is reached. In contrast to the unloader valve, the delayed unloader valve is always open and has delayed closing properties.

Repeatability



The permissible tolerance of the switching values (repeatability) is ± 4 Psi .

Service

Our service offers you the possibility of carrying out pressure settings depending on your requirements. We, of course, can also mount any accessories you may need on demand, profiting at the same time from a complete warrantee.



Warning: Please read the instruction manual carefully before installation and usage and be sure that the installation is made by professionals only!

1. Application and advantage

Air compressor pressure control model L7161181 is designed for the control of starting and stopping of various kinds of air compressors. Being an indispensable auto-control device for air compressor, it can start and stop air compressor automatically according to the set Min. cut-in pressure and max. cut-off pressure. Owing to the principle of auto-control, air inside the compressor can be kept within certain range without further manual control. Moreover as the air compressor and its motor only work intermittently, the life span is prolonged, the efficiency of the compressor is explored and electricity consumption is saved as well.

2. Main construction diagram and notice

The main construction diagram of the pressure control model L7161181 is shown as below Fig. 1. with two normally closed contacts inside. Main spring No.2 and minor spring No.5 function as the pressure springs for the pressure control to control the air compressor to start and stop automatically at the set pressure range. The height of the above two springs, known as H1 and H2 are adjusted at the factory as per the set pressure range and marked at point of hexagon nut M4 (No.3) and hexagon self-lock nut M4 (No.4). Usually users are not suggested to change the above-mentioned two springs otherwise the pressure range of start and stop will be changed.

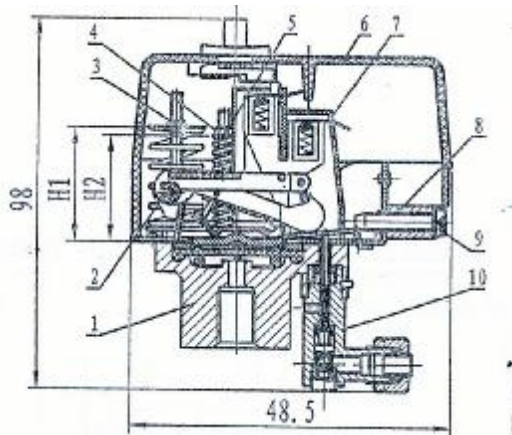

10	Elbow valve	1
9	Crossed Lock Screw	1
8	Wiring Clamp	1
7	Terminal Block Union	1
6	Cover Union	1
5	Minor Spring	1
4	Hexagon Self-lock Nut M4	1
3	Hexagon Nut M4	2
2	Main Spring	2
1	Base Union	1
No.	Name	QTY

Fig. 1 Main Construction Diagram

3. Main technical data and ratings:

Table 1 Electrical ratings

Rated AC Voltage (V)	Rated AC Current (A)	Rated Frequency (Hz)	Max. Power for Single Phase Motor
110、120	20	50/60	1.5HP
220、230、240	17	50/60	3 HP
Temperature limit for cables to be connected: 75°C			

Table 2 Pressure settings:

Various Pressure Range	1	2	3	4	5	6
Min Cut-in Pressure (PSI)	95±4	105±4	115±4	120±4	125±4	145±4
Max. Cut-off Pressure (PSI)	125±4	140±4	150±4	155±4	155±4	180±4
Differential Ratings (PSI)	30	35	35	35	30	35

4 Protection Grade

The outer enclosure of the pressure control acts as the terminal protection. Please follow the installation position as shown in Fig.2 during time of installation. The protection grade is IP44 in a vertical installation and IP41 in a horizontal installation.

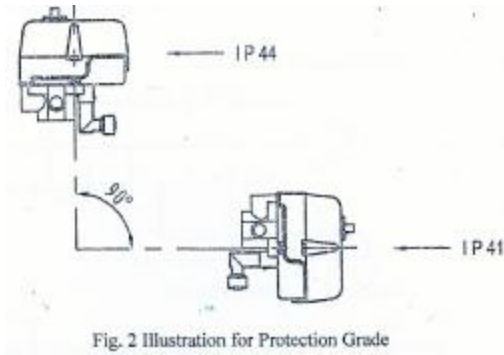

5 Installation Notice

Warning: Always cut off the power supply before any electrical and pneumatic connection to avoid any accidents!

5.1 Follow the vertical way of installation for the pressure control as shown in Fig. 2 to ensure higher protection grade.

5.2 Wiring diagram for the pressure control as per Fig. 3 for single phase air compressor motor

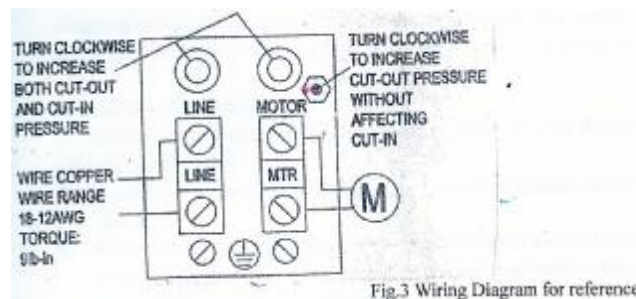
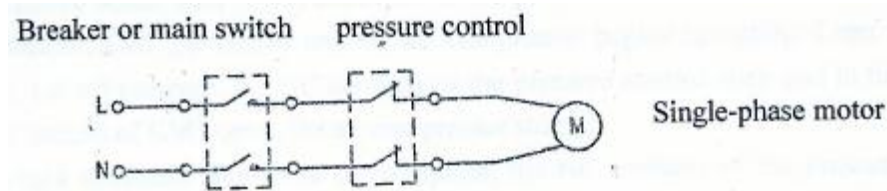

5.3 Electrical and pneumatic connection

5.3.1 Electrical connection to single phase motor (for reference)

- ① Turn the black knob on the cover to the position of “off”. Loosen the two screws at either sides of the cover with suitable Philips screwdriver to take off the “cover union” (No.6 in Fig. 1).
- ② Loosen the crossed lock screw (No. 9 in Fig 1) at the side of the base with suitable crossed screwdriver or hexagon socket wrench. Loosen the wiring clamp (No.8 in Fig. 1) for wiring connection. Insert the three-wired cable of the air compressor motor from the base of the pressure control and connect the ground wire with the right ground screw as shown in Fig .3. The other two wires shall be connected to the load side (shown as Motor in Fig. 3) of the terminal block (No 7 in Fig.1). Plug-in connector is recommend for the connection.
- ③ The connection for the power supply side can be followed in the same way as in the above. Insert the three-wired cable into the power connection side of the terminal block (No. 7 in Fig. 1) with the ground wire to the left ground screw as shown in Fig. 3 and the other two power line (L and N) to Line side as shown in Fig. 3. Also the plug-in connector is recommended in the wiring for L and N wire.
- ④ Push the wiring clamp (No. 8 in Fig. 1) back to the base after wiring connection and tighten the crossed lock screw (No. 9 in Fig.1). **Caution: Not to break the plastic insulation sleeve around the cable otherwise the insulation of the cable will be damaged.**
- ⑤ Put the cover back onto the pressure control, tighten the two fixing screws and restore the whole pressure control.

Pneumatic connection

- ① Connect one end of air pipe with suitable diameter to the elbow valve (No. 10 in Fig. 1) of the pressure control and the other end to the one-way valve of the air compressor.
- ② Put any sealant around the Z1/4” male pipe connection of the air tank of air compressor, then put the pipe connection into vertical Z1/4” female connector in the base union (No. 1 as shown in Fig. 1) of the pressure control. Be sure there is no leakage between the connections.
- ③ The other three horizontal Z 1/4” female connections in the base union (No. 1 in Fig. 1) of the pressure control are available for optional use and the installation can be followed as per No. ② in clause 5.3.2.
- ④ Good sealing without any leakage is required in all above connections and proper force is recommended in base connection to avoid any breaking of the four-way connector of the base union.

5.3.3 Check all electrical connections and pneumatic connections for mistake shooting and rectify if any.

5.3.4 Sequence of the above electrical connections and pneumatic connections is up to the users.

5.4 Pilot run

5.4.1 Pilot run can be made after installation. Check the black knob on the cover to be in the position of “off” before pilot operation. Be sure that the knob turn flexibly between “on” and “off”, otherwise make a second installation of the cover before pilot run. No automatic control will be effected if the black knob is at the position of “off” as the two contacts are cut open.

5.4.2 Energize the pressure control after checking as per 5.4.1. As the black knob is at the position of “off”, the pressure control is closed and the air compressor doesn’t work. If the black knob is turned to “on” position, the air compressor will start automatically. Usually when the pneumatic connection is made, air pressure inside tank is less than the min. cut-in pressure, the two contacts of the pressure control close and the circuit is connected and air

compressor begins its normal operation. When the air pressure inside tank increases to the max. cut-off pressure, the compressor stops automatically. Due to the air consumption, the pressure will be lower than the Min. cut-in pressure again and the circuit will be on again for another operation. The repeated cycles of auto-start and auto-stop prove a good pilot run for the normal operation.

6 Typical faults during pilot run and normal operation

6.1 Motor of the air compressor doesn't work even if the pressure inside tank is less than the min cut-in pressure: Turn the black knob to the position of "off" and cut off the power supply for a detailed check: Anything wrong in the circuit connection? Any oxidation on the terminals of the plug-in connector or the terminals of the terminal block? The circuit won't be on in case of any loosening terminals or bad electrical contacting.

6.2 The air compressor doesn't stop: Turn the black knob to the position of "off" and cut off the power supply for a detailed check: Anything wrong in circuit connection? Any leakage within the pneumatic circuit which causes the air pressure inside tank less than the max cut-off pressure? Any welding of movable and fixed contacts after long time using or caused by abnormal operation?

If circuit doesn't stop due to the welding of the movable and fixed contacts after long time normal operation then usually the life for these two contacts are over and must be replaced by new pressure control. If the welding happens due to abnormal reasons, **then all these reasons must be carefully looked into and rectified before replacement.**

Disassembling and repairs by professionals only!

6.3 The air compressor can be always on without stop if there is obvious leakage within the pneumatic circuit or the air consumption is too large, therefore the air pressure is always less than the max cut-off pressure. In this way the quality of the pressure control doesn't matter, the problem can be corrected by reducing the air consumption and leakage rectifying.

All these faults can be corrected by relevant measures according to the reasons. Try another pilot run before normal operation.

7. Wiring diagram to three-phase motor shown as in Fig. 4 (for reference)

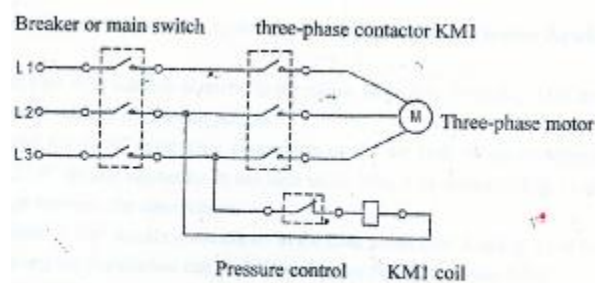

Fig. 4 Wiring diagram to three-phase motor (for reference)

7.1 The pressure control can also be used for the control of three phase motor with high power. The wiring diagram can be referred to Fig. 4 in the above. In this way, one set of three-phase AC contactor KM1 with the power setting suitable for the motor is used. The contacts of the pressure control can be connected in series with the coil of the contactor then connected to any two live wires.

7.2 Make the breaker closed. If the pressure control is run for the first time, then the two normally closed contacts are closed due to that the air pressure inside tank is less than min. cut-in pressure, therefore coil KM1 get energized and the NO contacts of the contactor KM1 get closed and the air compressor begins operating. Later on when the air pressure gets to be the max. cut-off pressure, the NC contacts of the pressure control open and in turn the coil KM1 get de-energized and the NO contact of KM1 open, the air compressor stops.

When air pressure inside tank decreases due to air consumption, the NC contacts of the pressure control closed energizing the coil KM1 and the air compressor operates again. The repeated cycles of auto-start and auto-stop prove a good pilot run for the normal operation. As for other information, please refer to clause 5&6.

8 Safety Operation Rules

△ Read the instruction manual in details and follow the installation and operation carefully to avoid any electrical shock and fire:

- I Always unplug the pressure control and cut off the mains before any installation of or repairs to the device;**
- I Be sure that the cross section of the connection leads and its extension cable shall be in accordance with electrical power of the air compressor. Also the connection cable and the pressure control itself must be kept away from any source of water;**
- I The cross section of the cable to the pressure control must be in accordance with that's required by the contactor circuit if used for a three-phase air compressor and the ratings of the coil must be in compliance with the power supply circuit.**
- I Three-wired cable is recommended in the electrical connection of the circuit and the ground screw must be connected for the function of leakage current protecting. It is recommended to install suitable RCD to obtain higher leakage protection. Any requirements please refer to the installation instruction of the RCD;**
- I The black knob of the pressure control shall be set at the position of "on" during compressor operation and turn it to the position of "off" during non-operation for safety.**

Wiring Diagram

AIR COMPRESSOR CURCUIT DIAGRAM / SINGLE PHASE MOTOR 208-230V

