

TRADE SECRET –CONFIDENTIAL AND PROPRIETARY  
 EXCLUSIVELY OWNED BY LAPLANTE COMPRESSOR, LTD.,  
 ANY COPYING, USE OR DISCLOSURE WITHOUT THE WRITTEN  
 PERMISSION OF LAPLANTE COMPRESSOR, LTD. IS STRICTLY  
 PROHIBITED. THIS MATERIAL IS PROTECTED UNDER  
 TRADE SECRET AND UNFAIR COMPETITION LAWS. THE  
 EXPRESSION OF THE INFORMATION IS PROTECTED UNDER  
 FEDERAL COPYRIGHT LAWS. VIOLATIONS MAY RESULT IN  
 CIVIL AND CRIMINAL FINES AND PENALTIES.

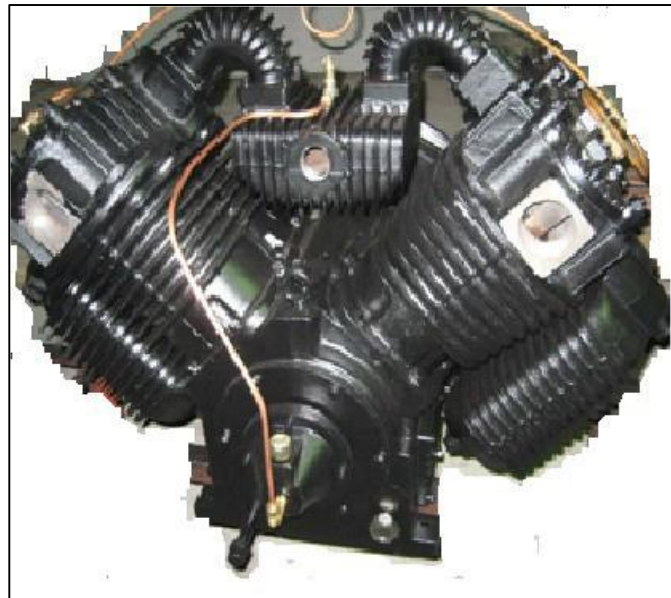
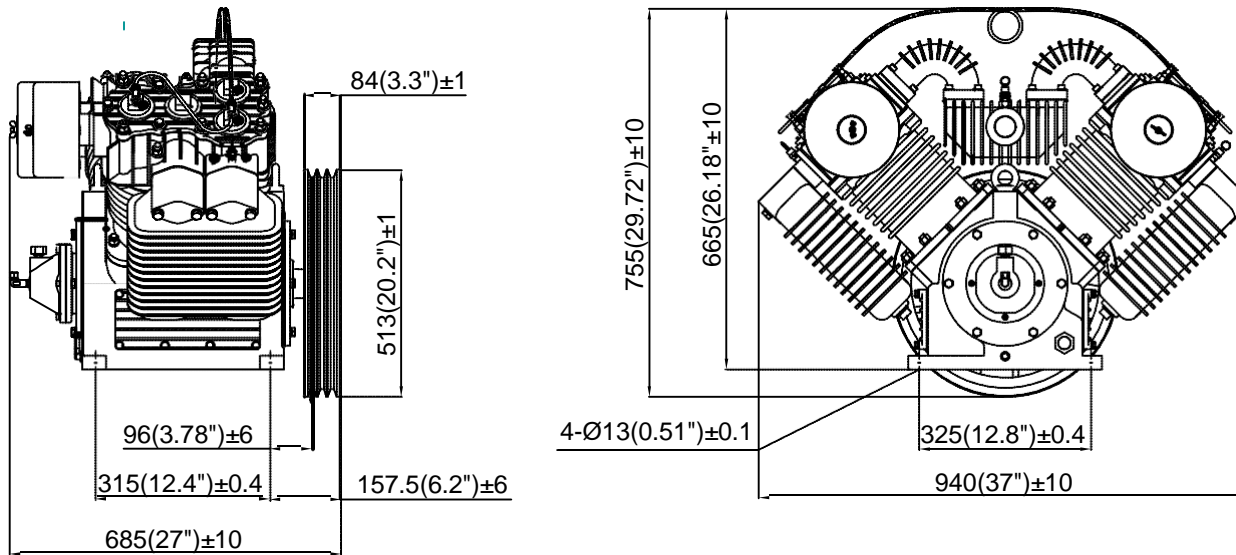

**SPECIFICATIONS:**

1. Power Range: 15 - 30HP / 11 - 22Kw
2. Maximum Pressure: 175 Psi / 12 Bar
3. Cylinder: 4
4. Bore LP: 6 1/8" / 155 mm, Bore HP: 3.25" / 82mm
5. Stroke: 4.5" / 116mm
6. RPM Min / Max: 500 / 800
7. Flywheel Dia. / Groove: 20.2" / 513 mm / 3B

**Features:**

1. Cast Iron Crankcase
2. Cast Iron Cylinder
3. Cast Iron Cylinder Head
4. Ductile Iron Crankshaft
5. Ductile Iron Conn. Rod
6. Bronze / Babbit Bearing Top / Bottom
7. Taper Bearings Crankshaft
8. Metal Breather and SS Sight Glass W / Float
9. Powder Coat Metal Filter Canister
10. Fill With ISO100 Lubricant Oil
11. Synthetic Lubricant as Optional
12. Discharge Port: ZG1 1/4" Female

**Standard Package:**

1. Single: 1 pc, Weight: 678Lbs / 308 Kg
- 2a. Crate: 3 Pcs/ 1 Crate (L220CM X W104CM X H91CM)
- 2b. 20' Container: 30 pcs; 40' Container: 66 pcs
- 3a. Crate: 1 PC/ 1 Crate (L104CM X W74CM X H91)
- 3b. 20' Container: 30 pcs; 40' Container: 66 pcs



Address : 1830 W. 15th Street Houston, TX 77008  
 Telephone : (713) 635-6291  
 Email : sales@lptexascompressor.com  
 Website : www.LPTexasCompressor.com