

TRADE SECRET –CONFIDENTIAL AND PROPRIETARY
 EXCLUSIVELY OWNED BY LAPLANTE COMPRESSOR, LTD.,
 ANY COPYING, USE OR DISCLOSURE WITHOUT THE WRITTEN
 PERMISSION OF LAPLANTE COMPRESSOR, LTD. IS STRICTLY
 PROHIBITED. THIS MATERIAL IS PROTECTED UNDER
 TRADE SECRET AND UNFAIR COMPETITION LAWS. THE
 EXPRESSION OF THE INFORMATION IS PROTECTED UNDER
 FEDERAL COPYRIGHT LAWS. VIOLATIONS MAY RESULT IN
 CIVIL AND CRIMINAL FINES AND PENALTIES.

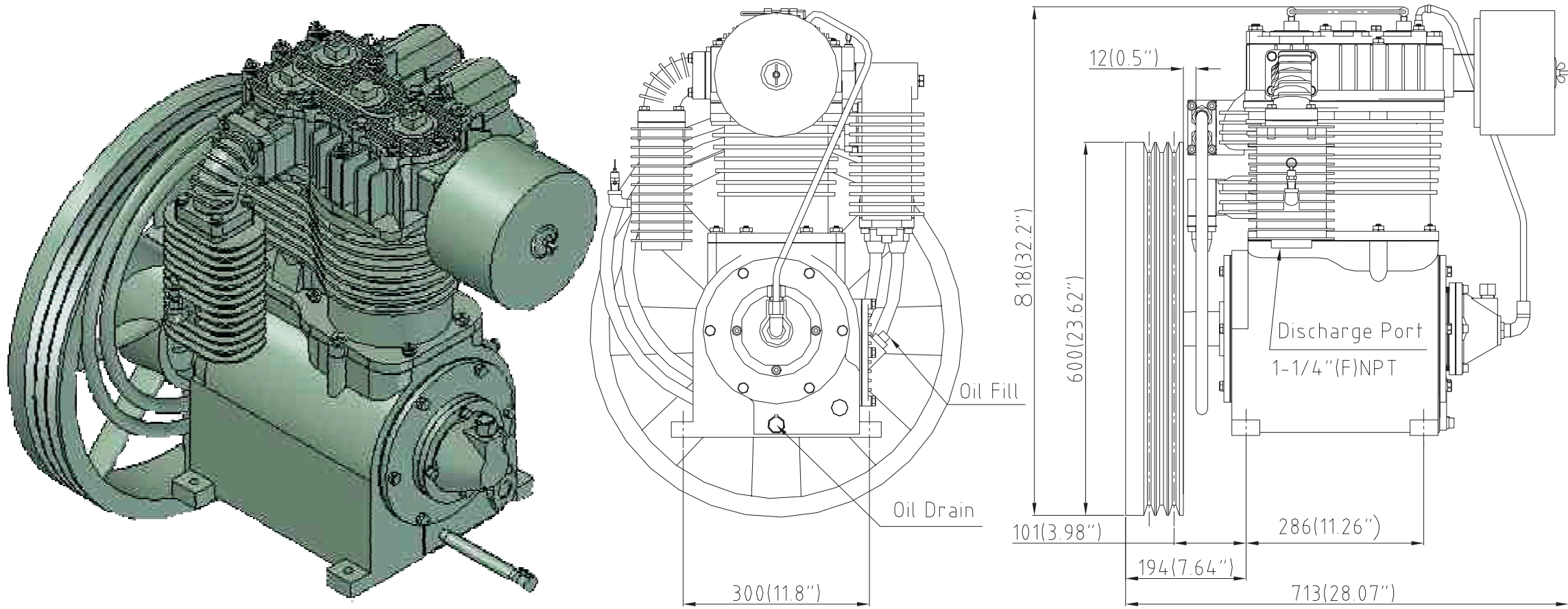

Specification:

- Power Range: 10~15HP/8~12.2Kw
- Maximum Pressure: 175Psi/12Bar
- Cylinders: 2
- Bore of LP: 6.10"/155mm
- Bore of HP: 3.35"/85mm
- Stroke:4.57"/116mm
- RPM:400~900
- Flywheel Dia./Groove: 24"/600mm/3B

Features:

- Cast Iron Crankcase
- Cast Iron Cylinder
- Cast Iron Cylinder Head
- Ductile Iron Crankshaft
- Ductile Iron Conn. Rod
- Centrifugal Unloader and Head Unloader
- Bronze Bushing Wrist Pin
- Babbitt Bearings Crankshaft
- Ball Main Bearings
- Steel Breather and Brass Sight Glass
- Power Coated Steel Filter Silencer
- Filled with DAB150 Lubricant
- Synthetic Lubricant as Option

Standard Package:

- Single : 1 Pcs,Weight:506B/230Kg
- Crate : 4 Pcs,Weight:2110LB/960Kg
- 20' Container : 56 Pcs
- 40' Container : 80Pcs

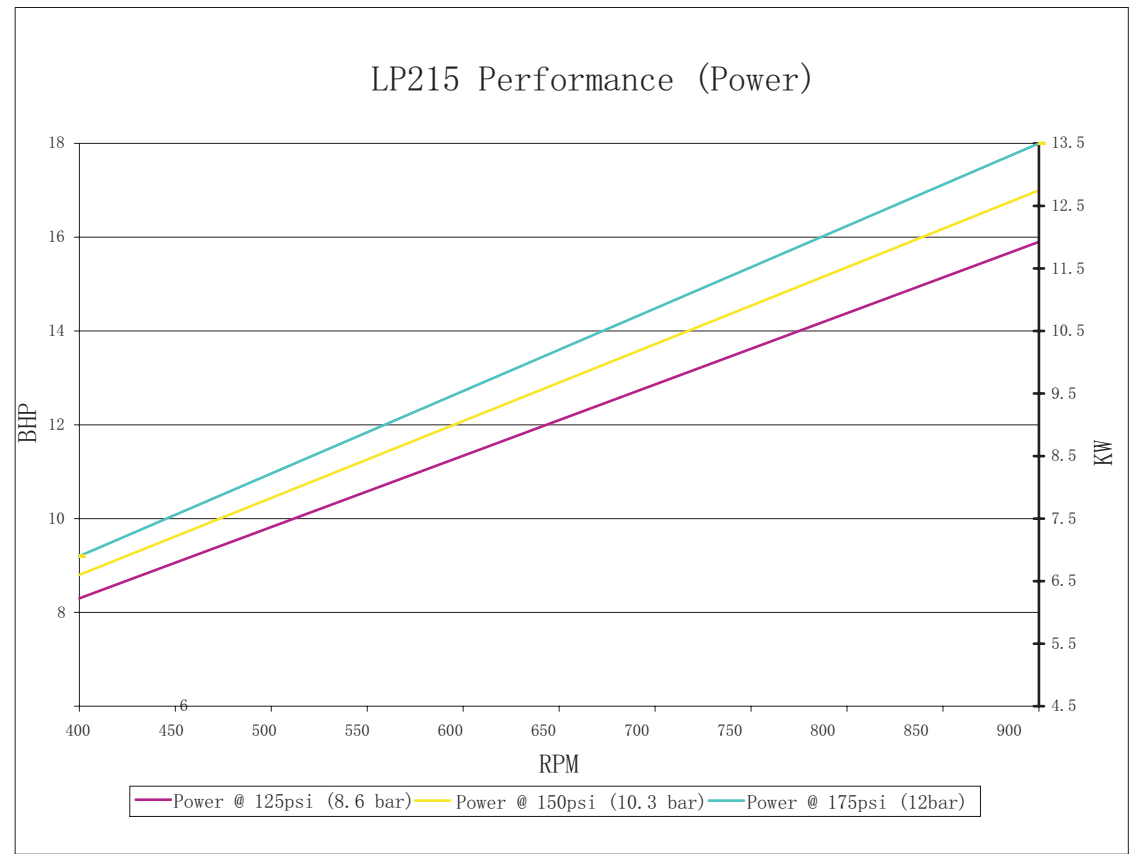

Address : 1830 W. 15th Street Houston, TX 77008
 Telephone : (713) 635-6291
 Email : sales@lptexascompressor.com
 Website : www.LPTexasCompressor.com

TITLE
LP215 Specifications